

ELECTRONIC PIANO

PF-500

Owner's Manual



Before using the PF-500, be sure to read "Precautions," on pages 3-4.

IMPORTANT

Check your power supply

Make sure that your local AC mains voltage matches the voltage specified on the name plate on the bottom panel. In some areas a voltage selector may be provided on the bottom panel of the main keyboard unit. Make sure that the voltage selector is set for the voltage in your area. The voltage selector is set at 240V when the unit is initially shipped. To change the setting use a "minus" screwdriver to rotate the selector dial so that the correct voltage appears next to the pointer on the panel.

SPECIAL MESSAGE SECTION

PRODUCT SAFETY MARKINGS: Yamaha electronic products may have either labels similar to the graphics shown below or molded/stamped facsimiles of these graphics on the enclosure. The explanation of these graphics appears on this page. Please observe all cautions indicated on this page and those indicated in the safety instruction section.

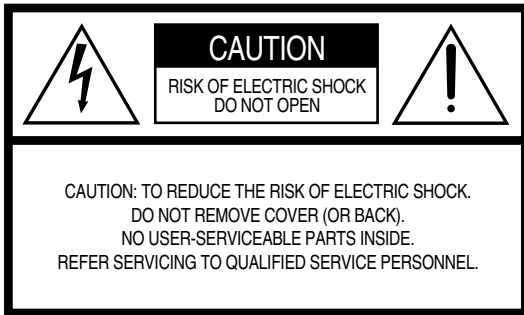

See bottom of Keyboard enclosure for graphic symbol markings



The exclamation point within the equilateral triangle is intended to alert the user to the presence of important operating and maintenance (servicing) instructions in the literature accompanying the product.

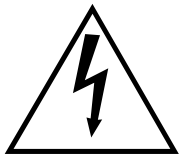

The lightning flash with arrowhead symbol, within the equilateral triangle, is intended to alert the user to the presence of uninsulated “dangerous voltage” within the product’s enclosure that may be of sufficient magnitude to constitute a risk of electrical shock.

IMPORTANT NOTICE: All Yamaha electronic products are tested and approved by an independent safety testing laboratory in order that you may be sure that when it is properly installed and used in its normal and customary manner, all foreseeable risks have been eliminated. DO NOT modify this unit or commission others to do so unless specifically authorized by Yamaha. Product performance and/or safety standards may be diminished. Claims filed under the expressed warranty may be denied if the unit is/has been modified. Implied warranties may also be affected.

SPECIFICATIONS SUBJECT TO CHANGE: The information contained in this manual is believed to be correct at the time of printing. However, Yamaha reserves the right to change or modify any of the specifications without notice or obligation to update existing units.

ENVIRONMENTAL ISSUES: Yamaha strives to produce products that are both user safe and environmentally friendly. We sincerely believe that our products and the production methods used to produce them, meet these goals. In keeping with both the letter and the spirit of the law, we want you to be aware of the following:

Battery Notice: This product MAY contain a small non-rechargeable battery which (if applicable) is soldered in place. The average life span of this type of battery is approximately five years. When replacement becomes necessary, contact a qualified service representative to perform the replacement.

Warning: Do not attempt to recharge, disassemble, or incinerate this type of battery. Keep all batteries away from children. Dispose of used batteries promptly and as regulated by applicable laws. Note: In some areas, the servicer is required by law to return the defective parts. However, you do have the option of having the servicer dispose of these parts for you.

Disposal Notice: Should this product become damaged beyond repair, or for some reason its useful life is considered to be at an end, please observe all local, state, and federal regulations that relate to the disposal of products that contain lead, batteries, plastics, etc.

NOTICE: Service charges incurred due to lack of knowledge relating to how a function or effect works (when the unit is operating as designed) are not covered by the manufacturer’s warranty, and are therefore the owners responsibility. Please study this manual carefully and consult your dealer before requesting service.

NAME PLATE LOCATION: The graphic below indicates the location of the name plate. The model number, serial number, power requirements, etc., are located on this plate. You should record the model number, serial number, and the date of purchase in the spaces provided below and retain this manual as a permanent record of your purchase.

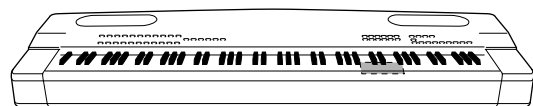

PF-500

Model _____

Serial No. _____

Purchase Date _____

PRECAUTIONS

PLEASE READ CAREFULLY BEFORE PROCEEDING

* Please keep this manual in a safe place for future reference.

WARNING

Always follow the basic precautions listed below to avoid the possibility of serious injury or even death from electrical shock, short-circuiting, damages, fire or other hazards. These precautions include, but are not limited to, the following:

Power supply/Power cord

- Only use the voltage specified as correct for the instrument. The required voltage is printed on the name plate of the instrument.
- Check the electric plug periodically and remove any dirt or dust which may have accumulated on it.
- Use only the supplied power cord/plug.
- Do not place the power cord near heat sources such as heaters or radiators, and do not excessively bend or otherwise damage the cord, place heavy objects on it, or place it in a position where anyone could walk on, trip over, or roll anything over it.

Do not open

- Do not open the instrument or attempt to disassemble the internal parts or modify them in any way. The instrument contains no user-serviceable parts. If it should appear to be malfunctioning, discontinue use immediately and have it inspected by qualified Yamaha service personnel.

Water warning

- Do not expose the instrument to rain, use it near water or in damp or wet conditions, or place containers on it containing liquids which might spill into any openings.
- Never insert or remove an electric plug with wet hands.

Fire warning

- Do not put burning items, such as candles, on the unit. A burning item may fall over and cause a fire.

If you notice any abnormality

- If the power cord or plug becomes frayed or damaged, or if there is a sudden loss of sound during use of the instrument, or if any unusual smells or smoke should appear to be caused by it, immediately turn off the power switch, disconnect the electric plug from the outlet, and have the instrument inspected by qualified Yamaha service personnel.

CAUTION

Always follow the basic precautions listed below to avoid the possibility of physical injury to you or others, or damage to the instrument or other property. These precautions include, but are not limited to, the following:

Power supply/Power cord

- When removing the electric plug from the instrument or an outlet, always hold the plug itself and not the cord. Pulling by the cord can damage it.
- Remove the electric plug from the outlet when the instrument is not to be used for extended periods of time, or during electrical storms.
- Do not connect the instrument to an electrical outlet using a multiple-connector. Doing so can result in lower sound quality, or possibly cause overheating in the outlet.

Assembling the keyboard stand

- Read carefully this manual or the attached documentation explaining the assembly process. Failure to assemble the stand in the proper sequence might result in damage to the instrument or even injury.

Location

- Do not expose the instrument to excessive dust or vibrations, or extreme cold or heat (such as in direct sunlight, near a heater, or in a car during the day) to prevent the possibility of panel disfiguration or damage to the internal components.
- Do not use the instrument in the vicinity of a TV, radio, stereo equipment, mobile phone, or other electric devices. Otherwise, the instrument, TV, or radio may generate noise.
- Do not place the instrument in an unstable position where it might accidentally fall over.
- Before moving the instrument, remove all connected cables.
- Do not place objects in front of the instrument's air vent, since this may prevent adequate ventilation of the internal components, and possibly result in the instrument overheating.

Connections

- Before connecting the instrument to other electronic components, turn off the power for all components. Before turning the power on or off for all components, set all volume levels to minimum. Also, be sure to set the volumes of all components at their minimum levels and gradually raise the volume controls while playing the instrument to set the desired listening level.

Maintenance

- When cleaning the instrument, use a soft, dry or slightly damp cloth. Do not use paint thinners, solvents, cleaning fluids, or chemical-impregnated wiping cloths.

Handling caution

- Never insert or drop paper, metallic, or other objects into the gaps on the panel or keyboard. If this happens, turn off the power immediately and unplug the power cord from the AC outlet. Then have the instrument inspected by qualified Yamaha service personnel.
- Do not place vinyl, plastic or rubber objects on the instrument, since this might discolor the panel or keyboard.
- Do not rest your weight on, or place heavy objects on the instrument, and do not use excessive force on the buttons, switches or connectors.
- Do not operate the instrument for a long period of time at a high or uncomfortable volume level, since this can cause permanent hearing loss. If you experience any hearing loss or ringing in the ears, consult a physician.

Using the bench (If included)

- Do not place the bench in an unstable position where it might accidentally fall over.
- Do not play carelessly with or stand on the bench. Using it as a tool or step-ladder or for any other purpose might result in accident or injury.
- Only one person should sit on the bench at a time, in order to prevent the possibility of accident or injury.
- If the bench screws become loose due to extensive long-term use, tighten them periodically using the included tool.

Saving data

Saving and backing up your data

- Current data (see page 43) is lost when you turn off the power to the instrument. Save the data to the storage memory (see page 43).

Yamaha cannot be held responsible for damage caused by improper use or modifications to the instrument, or data that is lost or destroyed.

Always turn the power off when the instrument is not in use.



Thank you for choosing the Yamaha PF-500 electronic piano. In order to make the most of your PF-500's performance potential and features, please read this Owner's Manual thoroughly, and keep it in a safe place for later reference.

About this Owner's Manual and Reference Booklet

This manual consists of four main sections: "Introduction," "Basic Operation," "Detailed Settings," and "Appendix." Also, a separate "Reference Booklet" is provided.

Introduction: Please read this section first. In the "Application Index" section on page 9 and "Features" on page 12, you can learn how to use the PF-500 and its functions in particular situations.

Basic Operation: This main section explains how to use the basic functions. Refer to this section while you play the PF-500. If you have questions or come across the words you do not know, refer to the section entitled "Questions about Operations and Functions" on page 90, or the "Index" on page 102.

Detailed Settings: This section explains how to make detailed settings for the PF-500's various functions. Refer to this section as necessary.

Appendix: This section introduces troubleshooting, a description of preset voices, and other reference material.

Reference Booklet: XG Voice List, MIDI Data Format, etc.

- The illustrations and LCD screens as shown in this Owner's Manual are for instructional purposes only, and may appear somewhat different from those on your instrument.
- Copying of the commercially available software is strictly prohibited except for your personal use.

COPYRIGHT NOTICE

This product incorporates and bundles computer programs and contents in which Yamaha owns copyrights or with respect to which it has license to use others' copyrights. Such copyrighted materials include, without limitation, all computer software, MIDI files, WAVE data and sound recordings. Any unauthorized use of such programs and contents outside of personal use is not permitted under relevant laws. Any violation of copyright has legal consequences. **DON'T MAKE, DISTRIBUTE OR USE ILLEGAL COPIES.**

■ Trademarks

- Apple and Macintosh are trademarks of Apple Computer, Inc., registered in the U.S. and other countries.
 - Windows is the registered trademark of Microsoft® Corporation.
- All other trademarks are the property of their respective holders.

Table of contents

Introduction	2
PRECAUTIONS	3
About this Owner's Manual and Reference Booklet	5
Table of contents	6
Application Index	9
Included Accessories	11
Features	12
Before Using the PF-500	14
About the pedal unit	14
About the music stand	14
Turning the power on	15
Adjusting the display contrast	16
Setting the volume	16
Using headphones	16
Basic Operation	17
Part Names	18
Listening to the Demonstration Tunes	20
Listening to 50 Piano Preset Songs	22
Playing the 50 piano preset songs	22
Practicing a one-hand part using 50 preset songs	24
Selecting and Playing Voices	26
Selecting Voices	26
Using the pedals	27
Adding variation to the sound	
[BRILLIANCE]/[REVERB]/[CHORUS]	28
Combining two voices (Dual mode)	30
Splitting the keyboard range and playing two different voices (Split mode)	32
Using the metronome	34
Recording Your Performance	35
Recording a New Song	35
Recording to [TRACK 1]	35
Re-recording TRACK 1	37
Re-recording TRACK 1 partially	38
Recording to [TRACK2]	39
Recording to the third or more tracks [EXTRA TRACKS]	40
Other recording techniques	40
Adding data to or recording over an existing song	40
Changing a voice or tempo after recording	41
Adjusting the volume balance between playback and your performance [SONG BALANCE]	42
Recording in Dual or Split mode	42
Saving Recorded Songs and Handling the Files...[FILE]	43
PF-500 memory	43
Basic file operation	44
Saving recorded or other songs to PF-500 Storage memory...[SaveToMemory]	45
Deleting a Memory song...[DeleteSong]	46

Renaming a song...[RenameSong]	47
Changing the type of characters on screen...[CharacterCode]	47
Playing Back Recorded Songs	48
Playing back a song	48
Turning track playback on and off.....	50
Supported song data type	50
Connections	51
Connectors	51
Connecting a personal computer	53

Detailed Settings 59

Detailed Settings.....	60
Parameter List	60
Making detailed settings	63
Detailed settings for recording and playback [SONG SETTING]	65
Correcting note timing [Quantize]	65
Specifying whether playback starts immediately along with the first voicing [QuickPlay]	66
Auditioning the channels [ChannelListen]	66
Deleting data from each channel [ChannelClear].....	66
Specifying the range and playing back repeatedly [FromToRepeat]	66
Playing back the phrase specified by the phrase number [PhraseMark]	67
Playing back a song repeatedly [SongRepeat]	67
Detailed settings for the metronome METRONOME [SETTING]	68
Setting the metronome time signature [TimeSignature].....	68
Setting the metronome volume level [MetronomeVolume].....	68
Selecting the metronome voice [MetronomeSound]	68
Detailed settings for the voices [VOICE SETTING]	69
Setting the octave [Octave].....	70
Setting the volume level [Volume]	70
Setting the position of right and left channels [Pan]	70
Make fine adjustments to the pitch (only in Dual mode) [Detune]	70
Selecting the reverb type [ReverbType]	71
Setting the reverb depth [ReverbSend].....	71
Selecting the chorus type [Chorus Type].....	71
Setting the chorus depth [ChorusSend]	71
Setting the chorus on/off [ChorusOnOff]	72
Selecting the DSP type [DSP Type (DSP)]	72
Setting the speed of the vibraphone vibrato effect [VibeRotorSpeed].....	72
Turning the vibraphone vibrato effect on/off [VibeRotorOnOff (RotorOnOff)]	73
Setting the rotation speed of the rotary speaker [RotarySpeed (Rot.Speed)].....	73
Adjusting the depth of the DSP effect [DSPDepth]	73
Adjusting the brightness of the sound [Brightness].....	73
Adjusting the resonance effect [HarmonicContent (Harmonic)]	73
Adjusting the low-range frequency of the equalizer [EQ LowFreq. (EQ L.Freq)]	74
Adjusting the low-range gain (amount of boost/cut) of the equalizer [EQ LowGain].....	74
Adjusting the high-range frequency of the equalizer [EQ HighFreq. (EQ H.Freq)]	74
Adjusting the high-range gain (amount of boost/cut) of the equalizer [EQ HighGain]	74

Table of contents

Setting the touch sensitivity [TouchSense].....	75
Setting the right pedal function [RPedal].....	75
Setting the center pedal function [MPedal].....	75
Setting the left pedal function [LPedal].....	76
Setting the auxiliary pedal function [AuxPedal].....	76
MIDI [MIDI SETTING].....	77
About MIDI.....	77
Setting the MIDI transmit channel [MidiOutChannel].....	78
Setting the MIDI receive channel [MidiInChannel].....	78
Setting Local control on/off [LocalControl].....	79
Selecting performance from the keyboard or song data for MIDI transmission [MidiOutSelect].....	79
Selecting a type of data received via MIDI [ReceiveParameter].....	79
Selecting a type of data transmitted via MIDI [TransmitParameter].....	79
Transmitting the initial settings on the panel [InitialSetup].....	80
Executing voice data bulk dump [VoiceBulkDump].....	80
Other settings.....	81
Selecting a touch response [TouchResponse].....	81
Fine tuning the pitch [Tune].....	81
Selecting a tuning curve for a piano voice [PianoTuningCurve].....	81
Selecting a scale [Scale].....	82
Specifying the Split Point [SplitPoint].....	82
Changing the key [Transpose].....	82
Adjusting the depth of the Soft pedal [SoftPedalDepth].....	83
Depth of string resonance [StringResonanceDepth].....	83
Depth of sustain sampling for the damper pedal [SustainSamplingDepth].....	83
Specify the volume of the key-off sound [KeyOffSamplingDepth].....	83
Selecting a pedal function for vibraphone [VibraphonePedalMode].....	83
Assign the SONG [START/STOP] function to the pedal [PedalStart/Stop].....	84
Selecting a type of auxiliary pedal [AuxPedalType].....	84
Setting the point at which the damper pedal starts to affect the sound [HalfPedalPoint].....	84
Pitch bend range [PitchBendRange].....	84
Switch the speaker on/off [Speaker].....	85
Selecting items saved at shutdown [MemoryBackUp].....	85
Restoring the normal (default) settings [FactorySet].....	85
Other method for restoring the normal settings.....	85
Message List.....	86
Questions about Operations and Functions.....	90

Appendix 93

Troubleshooting.....	94
Data Compatibility.....	95
Preset Voice List.....	97
Voice Combination Examples (Dual and Split).....	99
Assembling the Keyboard Stand.....	100
Index.....	102

Application Index

Use this index to find reference pages that may be helpful for your application and situation.

Listening

- Listening to demo songs.....“Listening to the Demonstration Tunes” on page 20
“Playing the 50 piano preset songs” on page 22
- Listening to demo songs with different voices“Listening to the Demonstration Tunes” on page 20
- Listening to songs from “50 greats for the Piano” “Playing the 50 piano preset songs” on page 22
- Listening to my recorded performance “Recording to [TRACK 1]” on page 35
“Playing back a song” on page 48

Playing

- Using three pedals.....“Using the pedals” on page 27
- Playing an accompaniment that matches pitch “Changing the key [Transpose]” on page 82

Changing tonal color

- Viewing the list of voices..... “Preset Voice List” on page 97
- Simulating a concert hall..... “[REVERB]” on page 29
- Combining two voices..... “Combining two voices (Dual mode)” on page 30
- Playing different sounds with left and right hands
..... “Splitting the keyboard range and playing two different voices (Split mode)” on page 32
- Making a voice brighter and sharper, or softer and smoother “[BRILLIANCE]” on page 28
- Adding spread to the sound “[CHORUS]” on page 29

Practicing

- Muting the right- or left-hand part “Practicing a one-hand part using 50 preset songs” on page 24
- Practicing with an accurate and steady tempo.....“Using the metronome” on page 34
- Practicing using your recorded song “Recording Your Performance” on page 35
“Turning track playback on and off” on page 50

Recording

- Recording your performance “Recording Your Performance” on page 35
- Saving recorded songs to memory... “Saving Recorded Songs and Handling the Files...[FILE]” on page 43

Application Index

Use this index to find reference pages that may be helpful for your application and situation.

Settings

- Making detailed settings for recording and playback
..... “Detailed settings for recording and playback [SONG SETTING]” on page 65
- Making detailed settings for the metronome
..... “Detailed settings for the metronome METRONOME [SETTING]” on page 68
- Making detailed settings for the voices
..... “Detailed settings for the voices [VOICE SETTING]” on page 69
- Making detailed settings for MIDI “MIDI [MIDI SETTING]” on page 77
- Making detailed settings for the PF-500..... “Other settings” on page 81

Connecting the PF-500 to other devices

- What is MIDI?..... “About MIDI” on page 77
- Recording your performance “AUX OUT [R][L] Pin jacks (LEVEL FIXED), [R][L/L+R] Phone jacks” on page 52
- Raising the volume .. “AUX OUT [R][L] Pin jacks (LEVEL FIXED), [R][L/L+R] Phone jacks” on page 52
- Outputting other instruments’ sound from the PF-500..... “AUX IN [R], [L/L+R] jacks” on page 51
- Connecting a computer..... “Connecting a personal computer” on page 53

Assembling the keyboard stand

- Using the stand “Assembling the Keyboard Stand” on page 100

Quick solution

- What the PF-500 offers..... “Application Index” on page 9
..... “Features” on page 12
- Returning to the main screen..... “EXIT button” on page 18
- Resetting the PF-500 to the default setting
..... “Restoring the normal (default) settings [FactorySet]” on page 85
- Meaning of the messages..... “Message List” on page 86
- If you have questions about operations and functions
..... “Questions about Operations and Functions” on page 90
- Troubleshooting..... “Troubleshooting” on page 94

Included Accessories

Pedal Unit

Keyboard Stand

Music Stand

Bench (included or optional depending on locale)

Dust Cover (included or optional depending on locale)

Owner's Manual

Reference Booklet

Features

The Yamaha PF-500 electronic piano features rich sounds produced by Yamaha’s proprietary “**AWM dynamic stereo sampling**” tone generator system and a “**Graded Hammer**” keyboard that varies the key weight according to the key range, giving these electronic pianos a “playing-feel” that is very close to the keyboard of a genuine grand piano. The PF-500 GrandPiano1 voice features 3 velocity-switched samples (**Dynamic Sampling**), “**String Resonance**” (page 83) that recreates resonance of piano strings, special “**Sustain Sampling**” (page 83) that samples the unique resonance of an acoustic grand piano’s soundboard and strings when the damper pedal is pressed, and “**Key-off Samples**” that add the subtle sound produced when the keys are released. The PF-500 comes much closer to the sound of a true acoustic piano.

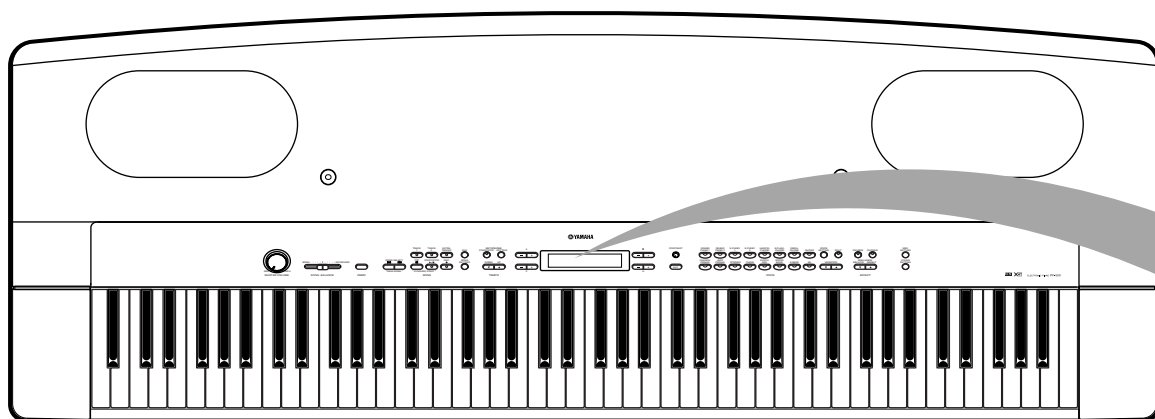

These jacks allow you to connect an external tone generator to reproduce the sound via the PF-500’s internal sound system and speakers. (page 51)

You can output the sound of the PF-500 from an external audio system, or connect it to a cassette tape recorder etc. and record your playing. (page 52)

A set of standard stereo headphones can be plugged in here for private practice. (page 16)

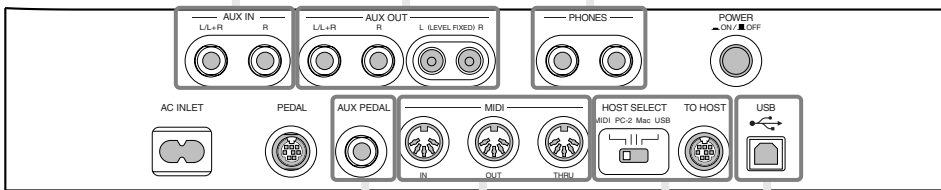

Connect an optional pedal here and assign one of the various functions to the pedal. (page 52)

Connect a MIDI device here to use various MIDI functions. (page 52, 56) (About MIDI—page 77)

This connector can be connected to your computer, allowing you to transfer MIDI data between the PF-500 and the computer. (page 52)

This jack and selector switch allow direct connection to a personal computer for sequencing and other music applications. (page 53–58)

SONG select buttons

This section enables you to listen to 50 piano preset songs, as well as to practice playing the songs using a convenient Practice function. You can also record and play back your performance. (page 22, 35, 48)

[FILE]

Save recorded songs and manage song files. (page 43)

[MIDI SETTING]

Make detailed MIDI settings, such as MIDI receive/transmit channels. (page 77)

[METRONOME]

Use the metronome functions. (page 34)

[REVERB] / [CHORUS]

Add reverb (reverberation) and spread (chorus) to the sound. (page 29)

[MASTER VOLUME]

Adjust the volume level using this dial. (page 16)

Voice group buttons

You can choose from sixteen groups of voices, including grand piano. You can also combine two sounds and use them together. (page 26)

[DEMO]

Demonstration playback is available for each voice. (page 20)

[CONTRAST]

Adjust the brightness of the display using this control. (page 16)

[SPLIT]

You can play different voices on the left- and right-hand sections of the keyboard. (page 32)

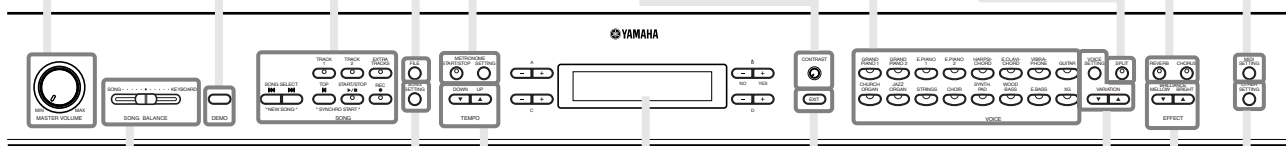

[SONG SETTING]

Make detailed settings for song recording and playback. (page 65)

The display allows accurate control and operation. (page 19)

[EXIT]

The screen returns to its main display when you press this button. (page 19)

[SONG BALANCE]

This lets you adjust the volume balance between the song playback and the sound you are playing on the keyboard. (page 42)

[VOICE SETTING] / [VARIATION]

You can make detailed settings for tone and effects. (page 69)

TEMPO [DOWN] [UP]

You can change the song tempo (speed). (page 23, 34, 36, 48)

BRILLIANCE [MELLOW] [BRIGHT]

Adjust the brightness of the tone using these buttons. (page 28)

[OTHER SETTING]

This lets you make detailed settings, such as adjusting the keyboard touch or making fine adjustments to the pitch. (page 81)

Before Using the PF-500

You do not need to install the stand to play the PF-500. However, if you wish to assemble the stand, refer to page 100.

About the pedal unit

Insert the plug of the pedal unit, with the arrow in the plug facing upward.

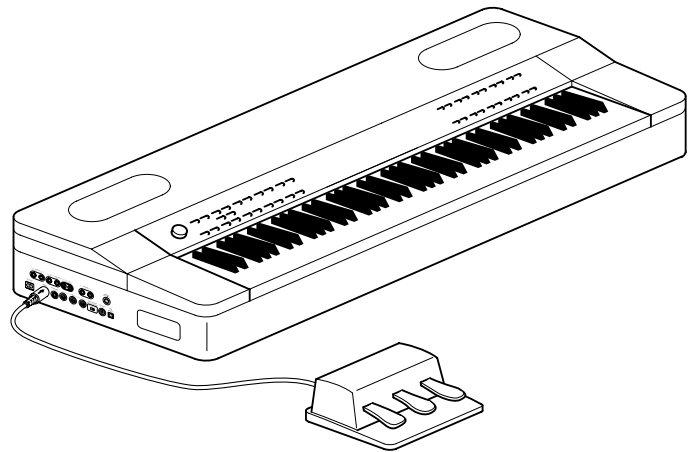

About the music stand

The PF-500 is supplied with a music stand that can be attached to the instrument by inserting it into the holes at the rear of the control panel.

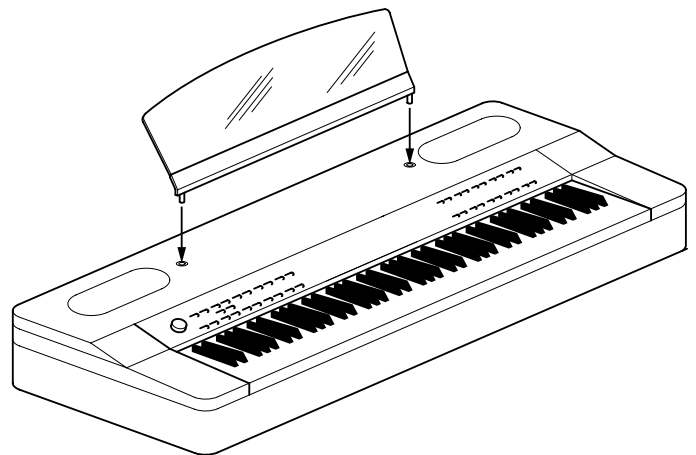

Turning the power on

1. Connect the power cable.

First insert the plug of the power cable into the [AC INLET] on the left side panel, then plug the other end of the cable into the proper AC outlet on the wall.

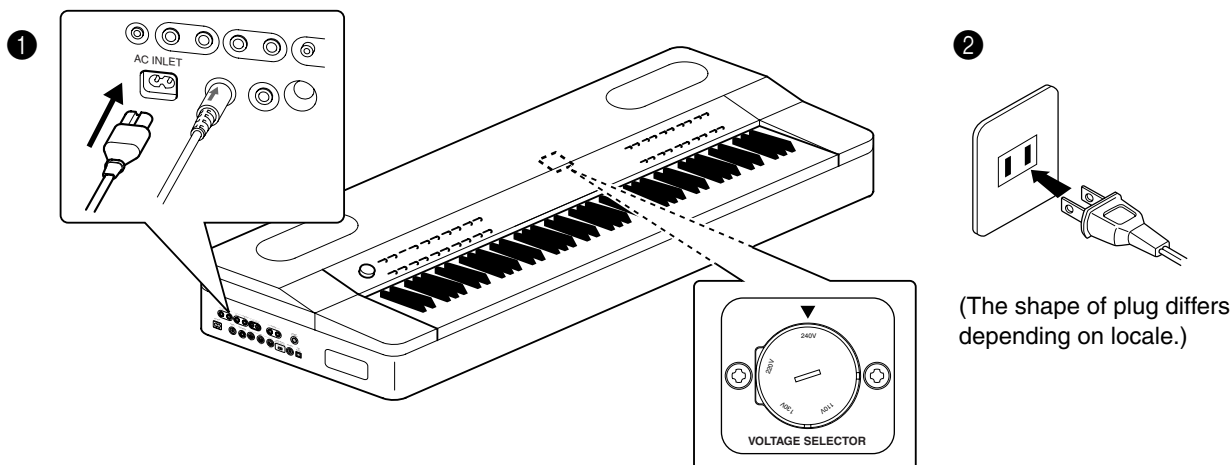

⚠ WARNING!

Make sure your PF-500 is rated for the AC voltage supplied in the area in which it is to be used (voltage rating appears on the name plate on the bottom panel). In some areas, a voltage selector may be provided on the bottom panel of the main keyboard unit. Make sure that the voltage selector is set for the voltage in your area. Connecting the unit to the wrong AC supply can cause serious damage to the internal circuitry and may even pose a shock hazard!

Use only the AC power cord supplied with the PF-500. If the supplied cord is lost or damaged and needs to be replaced, contact your Yamaha dealer. The use of an inappropriate replacement can pose a fire and shock hazard!

The type of AC power cord provided with the PF-500 may be different depending on the country in which it is purchased. (In some areas a plug adaptor may be provided to match the pin configuration of the AC wall outlets in your area.) Do NOT modify the plug provided with the PF-500. If the plug will not fit the outlet, have a proper outlet installed by a qualified electrician.

2. Turn on the power to the PF-500.

Press the [POWER] switch located on the left side panel to turn on the power.

- The screen located in the center of the front panel lights up.

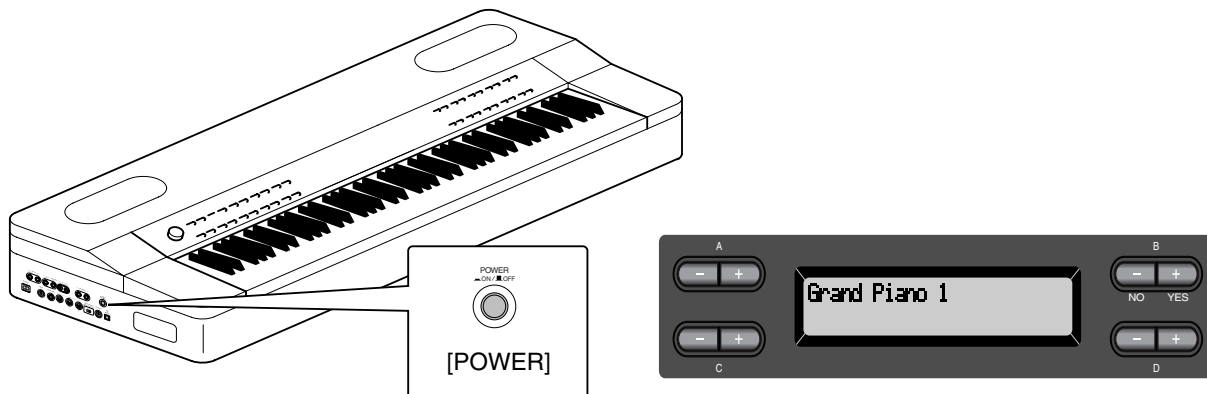

When you turn on the power to the PF-500, a voice name appears on the screen.

Press the [POWER] switch again to turn off the power to the PF-500.

Adjusting the display contrast

You can adjust the contrast of the display by turning the [CONTRAST] knob located to the right of the LCD.

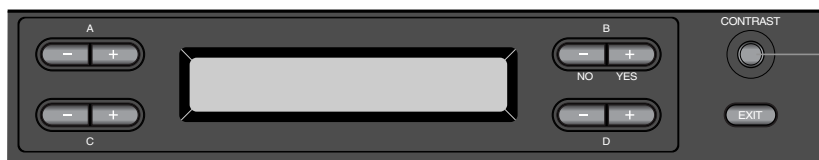

Use this knob.

TERMINOLOGY

CONTRAST:
difference between
brightness and dark-
ness

Setting the volume

To adjust the volume, use the [MASTER VOLUME] located at the left of the panel. Play the keyboard to actually produce sound while you adjust the volume.

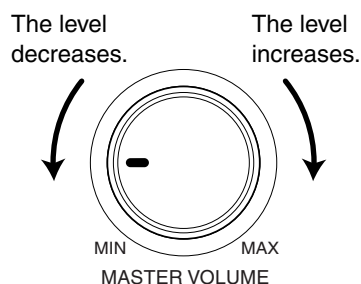

CAUTION

Do not use the PF-500 at a high volume level for a long period of time, or your hearing may be damaged.

TERMINOLOGY

MASTER VOLUME:
The volume level of the
entire keyboard sound

TIP

You can also adjust the [PHONES] output level, the AUX IN input level and the AUX OUT [L/L+R][R] output level using the [MASTER VOLUME] dial.

Using headphones

Connect a pair of headphones to one of the [PHONES] on the left side panel. Two [PHONES] jacks are provided. Two sets of standard stereo headphones can be plugged in. (If you are using only one pair of headphones, you can plug them into either of these jacks.)

CAUTION

Do not use headphones at a high volume for an extended period of time. Doing so may cause hearing loss.

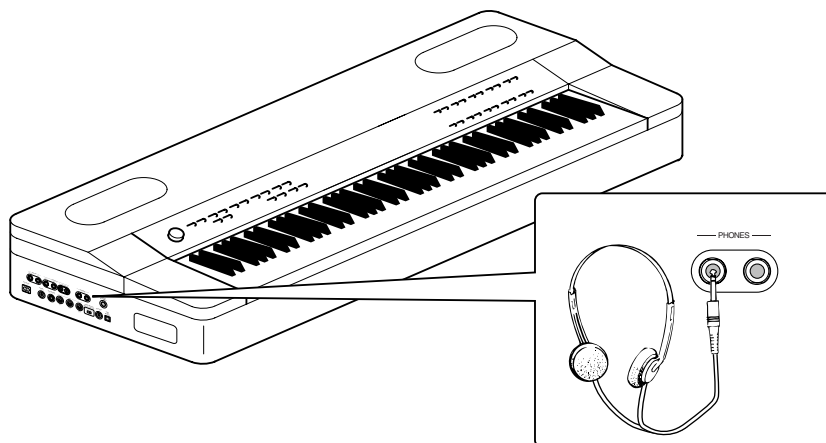

Basic Operation

Part Names

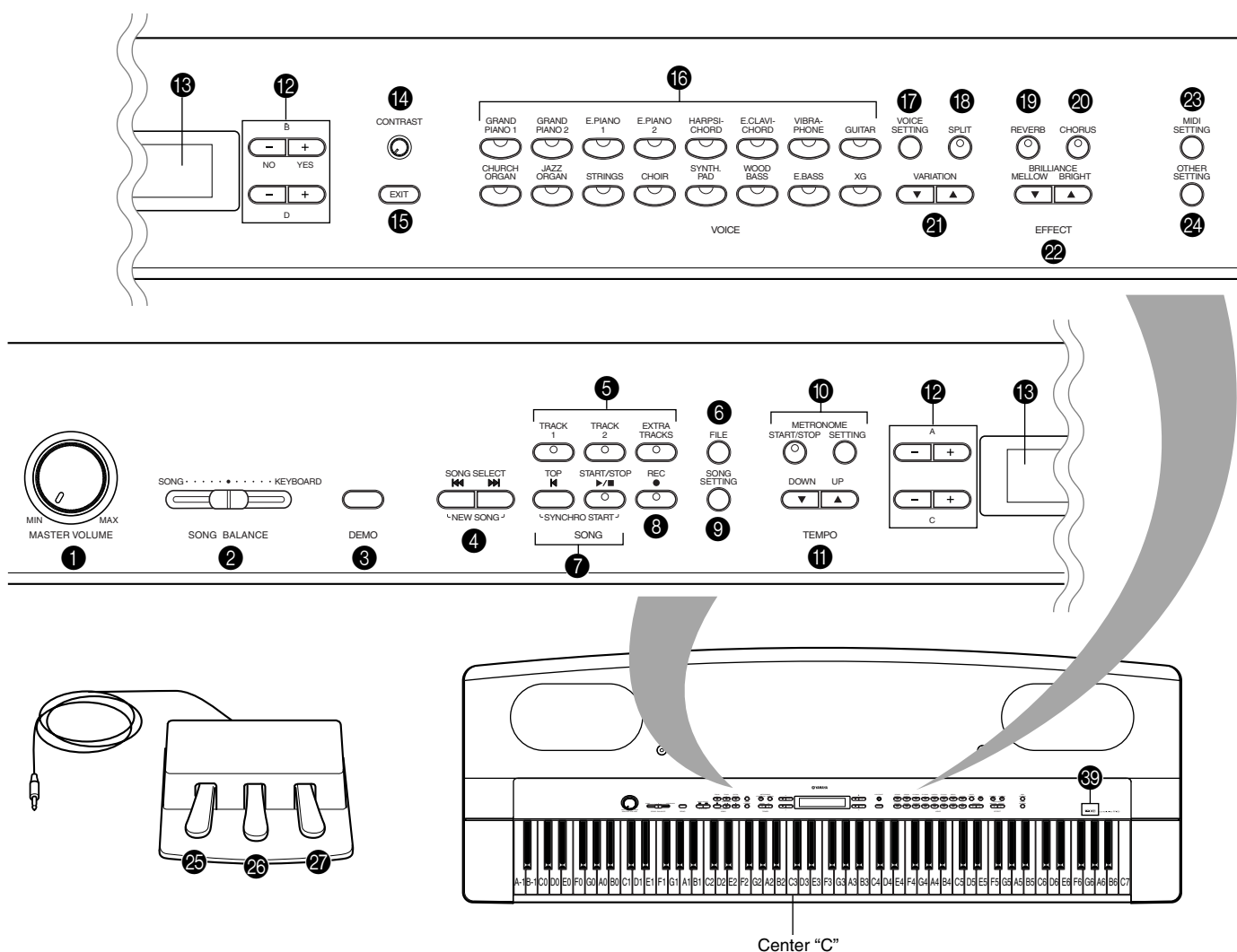

Top panel

- | | |
|--|--|
| ① [MASTER VOLUME]..... P16 | ⑬ LCD screen P19 |
| ② SONG BALANCE..... P42 | ⑭ [CONTRAST] knob P16 |
| ③ [DEMO] P20 | ⑮ [EXIT]..... P19 |
| ④ SONG SELECT [◀◀] [▶▶] P22, 35, 48 | ⑯ Voice group buttons P26 |
| ⑤ [TRACK1] [TRACK2] / [EXTRA TRACKS]..... P24, 35–40, 50 | ⑰ [VOICE SETTING] P69 |
| ⑥ [FILE] P43 | ⑱ [SPLIT] P32 |
| ⑦ [TOP] / SONG [START/STOP] P22, 36, 49 | ⑲ [REVERB] P29 |
| ⑧ [REC] P34 | ⑳ [CHORUS]..... P29 |
| ⑨ [SONG SETTING] P65 | ㉑ VARIATION [▼] [▲] P26 |
| ⑩ METRONOME [START/STOP] / [SETTING] P34, 68 | ㉒ BRILLIANCE [MELLOW] [BRIGHT] P28 |
| ⑪ TEMPO [DOWN] [UP] P23, 34, 36, 49 | ㉓ [MIDI SETTING] P77 |
| ⑫ LCD buttons A [-] [+] / B [- (NO)] [+ (YES)] / C [-] [+] / D [-] [+] P19 | ㉔ [OTHER SETTING] P81 |
| | ㉕ Soft pedal..... P27 |
| | ㉖ Sostenuto pedal..... P27 |
| | ㉗ Damper pedal P27 |

Connectors (Left side panel)

28 AUX IN.....	P51	34 [AUX PEDAL]	P52
29 AUX OUT	P52	35 MIDI [IN] [OUT] [THRU]	P52
30 [PHONES]	P16	36 HOST SELECT	P52
31 [POWER ON/OFF].....	P15	37 [TO HOST].....	P52
32 [AC INLET]	P15	38 [USB]	P52
33 [PEDAL].....	P14, 101		

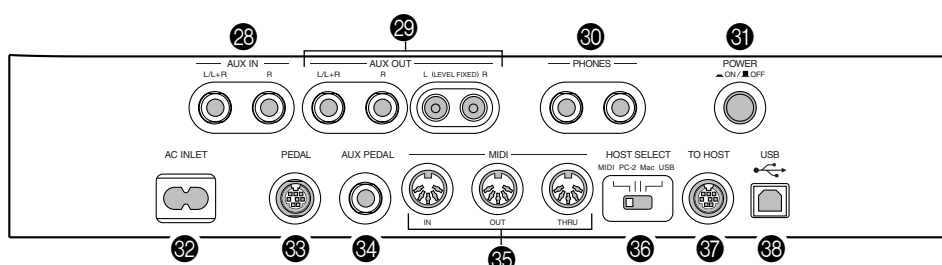

39 Panel logos



“GM System Level 1” is an addition to the MIDI standard which guarantees that any data conforming to the standard will play accurately on any GM-compatible tone generator or synthesizer from any manufacturer.



XG is a new Yamaha MIDI specification which significantly expands and improves on the “GM System Level 1” standard with greater voice handling capacity, expressive control, and effect capability while retaining full compatibility with GM.

13 LCD

Use the LCD button A, B, C, or D to select the contents displayed on the LCD.

Check the screen located in the center of the top panel after every operation. A voice name appears on the screen when you turn on the power to the unit.



15 [EXIT] button

When you press this button, the unit returns to the default screen (the screen that indicates a voice name(s) and is displayed when the power is turned on).

Listening to the Demonstration Tunes

For each voice group, the PF-500 contains one demo song that shows off the character of the voices. This section explains how to listen to the demo songs for the voice groups listed below.

Demonstration tunes

Voice group	Tunes	Composer
HARPSICHORD	Gavotte	J.S.Bach

The demonstration pieces listed above are short rearranged excerpts the original compositions.

All other songs are original (©2002 Yamaha Corporation).



Procedure

- Engage the demo mode.
Press the [DEMO] button to engage the demo mode.

The indicators of the voice group buttons will blink in succession.



TERMINOLOGY

Mode:

A mode is a status under which you can execute a certain function. In demo mode, you can play back demonstration tunes.

2. Select a tune and start playback.

Press the voice group button for the demo song that you want to hear.

The indicator of the voice group button you pressed will light, and the demo song will begin playing. Subsequently, the demo songs will play back consecutively from the upper left voice group button until you stop the playback.

3. Stop the playback.

Press the button of the voice group being played or the SONG [START/STOP] button.

4. Exit from demo mode.

Press the [DEMO] or [EXIT] button to exit from demo mode.

NOTE

To adjust the volume level of the demo songs, use the [MASTER VOLUME] dial.

TIP

To adjust the volume balance between the song playback and the sound you are playing on the keyboard, use the [SONG BALANCE] slider (page 42).

By holding down [DEMO] and pressing A[-][+] to get the [Piano-Demo] display, you can hear the piano demo. The piano demo lets you compare the result of enabling/disabling each sampling technology.

GRAND PIANO1	Stereo Piano (stereo sampling)
GRAND PIANO2	Mono Piano (mono sampling)
E.PIANO1	mezzo piano (dynamic sampling, mezzopiano)
E.PIANO2	mezzo forte (dynamic sampling, mezzoforte)
HARPSICHORD	forte (dynamic sampling, forte)
E.CLAVICHORD	with Sustain (with sustain sampling)
VIBRAPHONE	no Sustain (without sustain sampling)
GUITAR	with KeyOff (with key-off sampling)
CHURCH ORGAN	no KeyOff (without key-off sampling)
JAZZ ORGAN	with StringRes (with string resonance)
STRINGS	no StringRes (without string resonance)

Listening to 50 Piano Preset Songs

The PF-500 provides performance data of 50 piano songs. You can just listen to these songs (page 22) or use them for practice (page 24). See page 34 in the Reference Booklet for a complete listening of the preset songs.

Playing the 50 piano preset songs

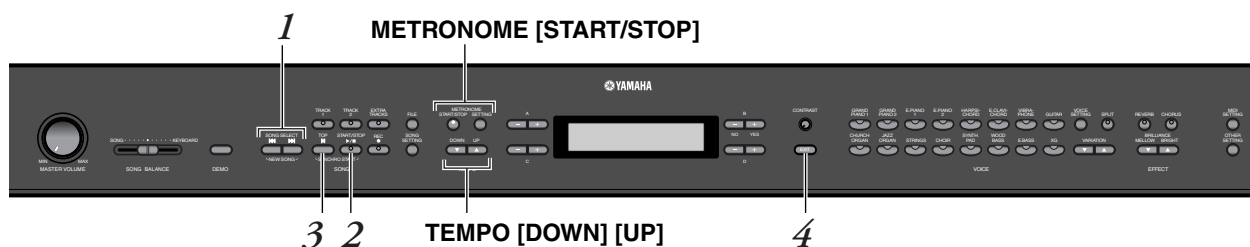

Procedure

1. Select a song.
Press one of the [SONG SELECT] buttons repeatedly to select the desired piano song from P-001 to P-050.

Song select screen



The song number appears on the display.

2. Play a preset song.
Press the SONG [START/STOP] button to start playback.

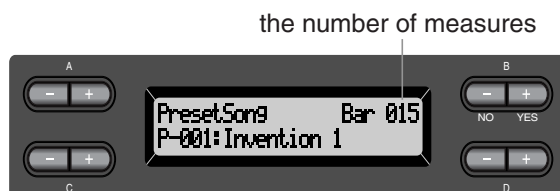

TERMINOLOGY

Song:

On the PF-500, performance data is called a “Song.” This includes demonstration tunes and piano preset tunes.

TIP

- You can also use the C [-]/[+] buttons to select a song after pressing the [SONG SELECT] button.
- [P-000: NewSong] is a blank song provided for you to record your performance. (See page 35.)
- Use the SongRepeat parameter in the “SONG SETTING” menu to select repeat playback of all songs or repeat playback of a single song. (See page 67.)

TIP

You can play the keyboard along with the preset song playback. You can change the voice playing on the keyboard.

Adjusting the tempo

You can use the TEMPO [DOWN]/[UP] buttons to adjust the playback tempo as required. The default tempo (the song's original tempo) is set when you press the [DOWN] and [UP] buttons simultaneously.

Press either of the SONG SELECT [◀◀]/[▶▶] buttons to return to the song select screen.

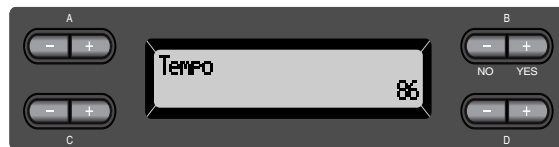

3. Stop the song playback.

When playback is complete, it automatically stops and the PF-500 locates the top of the song. To stop playback in the middle of a song, press the [TOP] button. You can also pause playback by pressing the SONG [START/STOP] button. Playback stops when you press the button.

Fast forward and rewind

You can perform the following operations in the song select screen:

- Use the B [-]/[+] buttons to move back and forth (rewind and fast forward) through the song while the song is played or stopped.
- Press the SONG SELECT [◀◀] or the C [-] button during playback to restart playback from the top of the song.
- Press the SONG SELECT [▶▶] or the C [+] button during playback to start playback from the next song.
- Press the SONG SELECT [◀◀] or the C [-] button while playback is stopped in the middle of the song to locate the top of the song.

4. Return to the default screen.

Press the [EXIT] button.

TIP

You can also use the D[-]/[+] buttons to change the tempo.

NOTE

Resetting the tempo

Whenever you select a new preset song, the tempo is automatically reset to the song's original value.

TERMINOLOGY

Default screen:

The default screen is a voice select screen (page 26) that appears when you turn on the power to the PF-500.

Practicing a one-hand part using 50 preset songs

The 50 preset songs have separate left- and right-hand parts on individual tracks. You can turn the left- and right-hand parts on or off as required so you can practice the corresponding part (the part that is turned off) on the keyboard. The right-hand part is played by [TRACK 1] and the left-hand part is played by [TRACK 2].



procedure

1. Turn off the playback part you wish to practice.
After you select a song to practice, press the [TRACK1] or [TRACK2] button to turn off the corresponding part.

When you first select a song, both [TRACK1] and [TRACK2] indicators light up, indicating that you can play back both parts. When you press one of the buttons to turn off playback, the corresponding button indicator turns off and the corresponding part playback is muted. Pressing the buttons repeatedly toggles between playback on and off.

2. Start playback and playing.
Press the SONG [START/STOP] button to start playback. Play the part you just turned off.

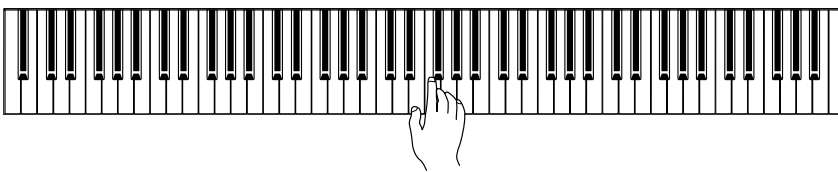

Starting playback automatically as you start playing the keyboard (Synchro Start)

You can cause playback to begin when you play the keyboard (Synchro Start).
Hold down [TOP] and press SONG [START/STOP]. The SONG [START/STOP] indicator will blink, and the PF-500 will wait for Synchro Start.
Now when you play the keyboard, playback will begin at the same moment.
If you press [TOP] while waiting, Synchro Start will be cancelled.

TIP

You can turn parts on or off, even during playback.

TERMINOLOGY

Synchro:
Synchronous; occurring at the same time

3. Stop playback.

When playback is complete, it automatically stops and the PF-500 locates the top of the song. If you wish to stop playback in the middle of a song, press the [TOP] button. You can also pause playback by pressing the SONG [START/STOP] button. Playback stops when you press the button.

You can also assign a phrase in a song to repeatedly practice that part. Refer to the [FromToRepeat] option in the “SONG SETTING” menu on page 66.

TIP

Resetting the part playback

Both parts are automatically turned ON whenever you select a new song.

Selecting and Playing Voices

Selecting Voices

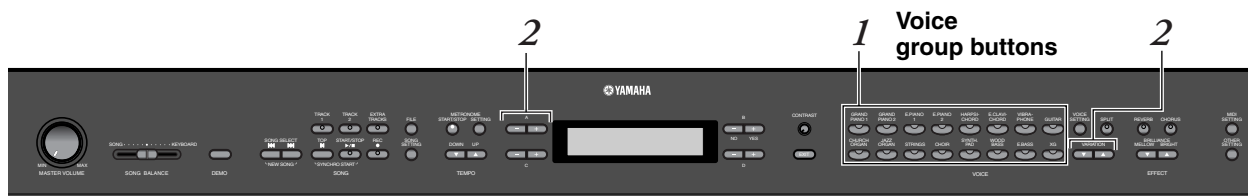

Procedure

1. Select a voice group.
Press a voice group button.
2. Select a voice.
Use VARIATION [▼][▲] or A [–][+] to select a voice.

If you select XG

If you select XG, you can select the XG voice group first, then select the desired voice.

- 2-1. Simultaneously press the [–][+] screen buttons located beside the XG voice name display, to access a screen where you can select XG voices.
- 2-2. Use A [–][+] to select the voice group.
- 2-3. Use C [–][+] to select the desired voice.

Voice group	Voice name	Voice group	Voice name
GRANDPIANO1	GrandPiano1	CHURCHORGAN	PipeOrganPrincipal
	MellowPiano		PipeOrganTutti
	RockPiano		PipeOrganFlute1
	HonkyTonkPiano		PipeOrganFlute2
GRANDPIANO2	GrandPiano2	JAZZORGAN	JazzOrgan
	BrightPiano		RotaryOrgan
E.PIANO1	E.Piano1		MELLOWORGAN
	SynthPiano	Strings	
E.PIANO2	E.Piano2	STRINGS	SynthStrings
	Vintage E.Piano		SlowStrings
HARPSICHORD	Harpsichord8'	CHOIR	Choir
	Harpsichord8'+4'		SlowChoir
E.CLAVICHORD	E.Clavichord		SCAT
	Wah Clavi.	SynthPad1	
VIBRAPHONE	Vibraphone	SYNTH.PAD	SynthPad2
	Marimba		WoodBass
	Celesta	WOOD BASS	Bass&Cymbal
GUITAR	NylonGuitar	E.BASS	ElectricBass
	SteelGuitar		FretlessBass
		XG	XGVoice

- For details on XG voices, refer to “XG voice list” (the separate data list booklet).

TERMINOLOGY

Voice

On the PF-500, a voice means “tone” or “tonal color.”

TIP

You can also switch between voices in the same group by pressing a voice group button repeatedly.

TIP

To learn characteristics of the voices, listen to demo songs for each voice group (page 20). Refer to “Preset Voice List” on page 97 for more information on characteristics of each preset voice.

TIP

You can control the loudness of a voice by how hard you play the keyboard, although different playing styles (touch sensitivities) have little or no effect with the sound of certain musical instruments. Refer to “Preset Voice List” on page 97.

TIP

XG is a major enhancement of the GM System level 1 format, and was developed by Yamaha specially to provide more voices and variations, as well as greater expressive control over voices and effects, and to ensure compatibility of data well into the future.

TIP

If you select XG and then simultaneously press the VARIATION [▼][▲] buttons, the XG voice select screen will appear.

Using the pedals

The PF-500 has three foot pedals: damper pedal (right), sostenuto pedal (center), and soft pedal (left) that produce a range of expressive effects similar to those produced by the pedals on an acoustic piano.

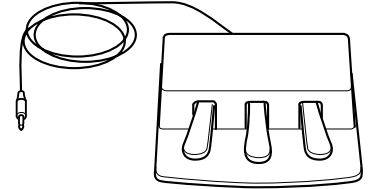

Damper (right) pedal

When you press the damper pedal, the notes you play have a longer sustain. When you select Grand Piano 1, pressing the damper pedal activates the instrument's special "Sustain Samples" to accurately recreate the unique resonance of an acoustic grand piano's soundboard and strings.



When you press the damper pedal here, the notes you play before you release the pedal have a longer sustain.

TIP

If the damper pedal doesn't work, or notes are sustained even when the pedal is not pressed, make sure that the pedal cord is properly plugged into the PEDAL jack on the unit (see page 14). Also, make sure that the RPedal parameter in the "VOICE SETTING" menu is set to ON (see page 75).

Sostenuto (center) pedal

If you play a note or chord on the keyboard and press the sostenuto pedal while holding the note(s), the notes will sustain as long as the pedal is held. All subsequent notes will not sustain.

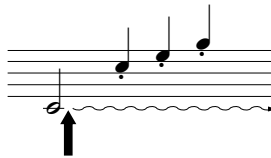

When you press the sostenuto pedal here while holding the note(s), the notes will sustain as long as you hold the pedal.

TIP

You can adjust the depth of the resonance produced by the "Sustain Samples" using the Sustain Sampling Depth parameter in the "OTHER SETTING" menu. (See page 83.)

Soft pedal (left)

The soft pedal reduces the volume and slightly changes the timbre of notes played while the pedal is pressed. (The soft pedal will not affect notes that are already playing when it is pressed. Press the pedal immediately before you play the target notes.)

With the Vibraphone and Jazz Organ voices, this pedal turns vibrato on and off or toggles the speed of vibrato. (See page 83.)

TIP

You can assign a function to each pedal via the "R Pedal", "M Pedal", and "L Pedal" parameters in the "VOICE SETTING" menu. (See pages 75, 76.)

TIP

The center and left pedals can also be assigned to song start/stop operation (START/STOP function) via the "PedalStart/Stop" parameter in the "OTHER SETTING" menu (on page 84).

Adding variation to the sound [BRILLIANCE]/[REVERB]/[CHORUS]

The Effect function enables you to add expression to the sound. The PF-500 effects include Brilliance, Reverb, and Chorus.



[BRILLIANCE]

You can use this control to adjust the brilliance of the tone and change the tonality to suit your preference.

Procedure

Press one of the BRILLIANCE [MELLOW]/ [BRIGHT] buttons to select the desired tonality.



- Mellow3 } Soft and mellow tone.
- Mellow2 } The sound becomes more mellow and rounder as the
- Mellow1 } number increases.
- Normal..... Standard tone

- Bright1 } Bright tone.
- Bright2 } The sound becomes brighter as the number increases.
- Bright3 }

Press the [EXIT] button to return to the main screen.

TIP

You can press BRILLIANCE [MELLOW] [BRIGHT], and then use D [-][+] to select the desired tonality.

TIP

Normal setting = Normal

TERMINOLOGY

Normal setting:
The "Normal setting" refers to the default setting (factory setting) obtained when you first turn on the power to the PF-500.

NOTE

If you select [Bright1], [Bright2] or [Bright3] as the type of brilliance, the volume level will increase slightly. Under this condition, if you raise the [MASTER VOLUME] dial setting, the sound may become distorted. In this case, lower the volume accordingly.

[REVERB]

This control adds reverberation to the sound by simulating the natural reverberation of a concert hall.

Procedure

Pressing the [REVERB] button repeatedly toggles the reverb on and off.

Even if the reverb effect is turned off, a “soundboard reverb” effect will be applied when the GrandPiano1 or GrandPiano2 voice is selected.

TIP

You can select a reverb type via the Reverb Type parameter in the “VOICE SETTING” menu, and adjust the reverb depth for the selected voice via the Reverb Send parameter. (See page 71.)

TIP

Normal setting = ON

[CHORUS]

This control adds spread and spaciousness to the sound.

Procedure

Pressing the [CHORUS] button repeatedly toggles the chorus on and off.

You can turn the chorus effect on and off by pressing the [CHORUS] ON/OFF buttons on the panel and by setting the Chorus On Off parameter in the VOICE SETTING menu (see page 72). The [CHORUS] ON/OFF button setting on the panel is temporary. That is, if you select another voice, the chorus setting for the previous voice is cancelled. The Chorus On Off parameter setting is saved for each voice. That is, if you select a given voice, the chorus setting is automatically turned on or off according to the saved chorus setting.

TIP

You can select a chorus type via the Chorus Type parameter in the “VOICE SETTING” menu, and adjust the chorus depth for the selected voice via the Reverb Send parameter. You can also turn chorus on or off via the Chorus On Off parameter. (See page 71.)

TIP

Normal Setting

The normal chorus on/off setting is different for each voice.

Combining two voices (Dual mode)

You can play two voices simultaneously across the entire range of the keyboard. In this way, you can simulate a melody duet or combine two similar voices to create a thicker sound. Refer to “Voice Combination Examples (Dual and Split)” on page 99 for examples of effective voice combinations.

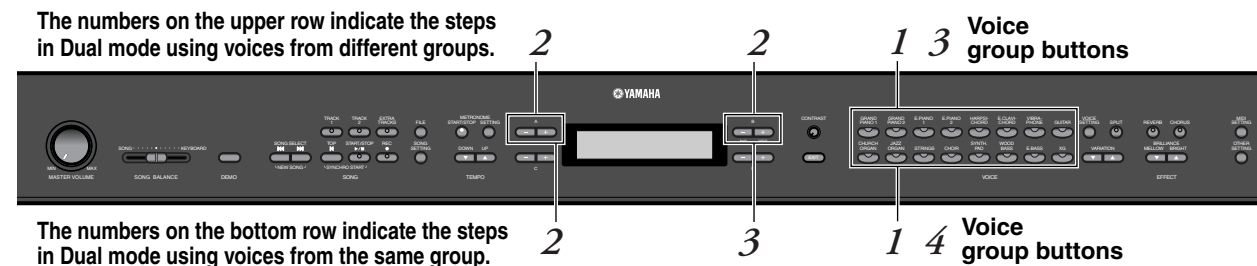

Dual mode using voices in different voice groups

Procedure

1. Enter Dual mode.

Press two voice group buttons simultaneously.

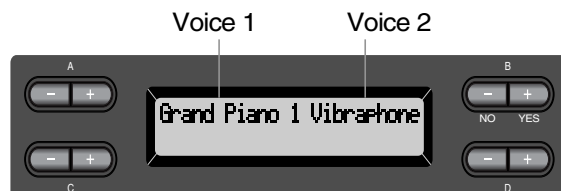

2. Select a voice.

Use the A [-]/[+] buttons and B [-]/[+] buttons to select a voice.

The voices listed in the upper row in “Preset Voice List” on page 97 are called voice 1, and those listed in the bottom row are called voice 2.

3. Exit Dual mode and return to normal play mode.

Press any voice group button.

TIP

If you want to select Dual mode for the left-hand area when the entire keyboard is divided into left and right areas (page 32), hold down [SPLIT] and simultaneously press two voice group buttons.

TIP

You can also use the VARIATION [▼]/[▲] buttons to select the voice 1.

TIP

Refer to page 26 for details on how to select XG voices.

Dual mode using voices in the same voice group

Procedure

1. Select a voice group.
In normal play mode, press the desired voice group button.
2. Select a voice.
Use the A [-]/[+] buttons to select a voice.
3. Select another voice.
Use the B [-]/[+] buttons to select another voice in the same voice group.

To use the identical voices, press the B [-]/[+] buttons once. To use different voices within the same voice group, press the B [-]/[+] buttons repeatedly.

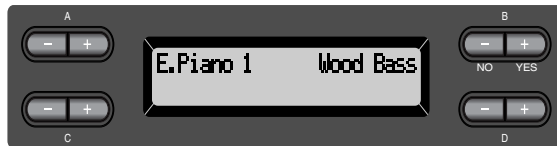

4. Exit Dual mode and return to normal play mode.
Press any voice group button.

TIP

If you want to select Dual mode for the left-hand area when the entire keyboard is divided into left and right areas (page 32), press D [-] [+].

Splitting the keyboard range and playing two different voices (Split mode)

Split mode enables you to play two different voices on the keyboard — one with the left hand and another with the right hand. For example, you can play a bass part using the [WOOD BASS] or [E. BASS] voice with the left hand, and a melody with the right hand. Refer to “Voice Combination Examples (Dual and Split)” on page 99 for examples of effective voice combinations.

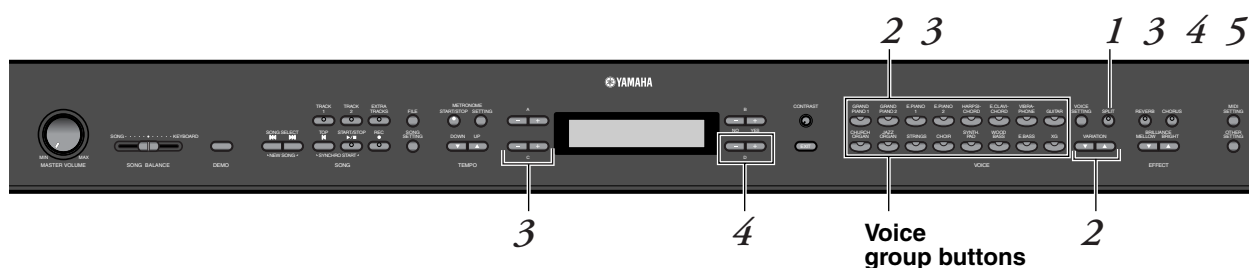

Procedure

1. Enter Split mode.
Press [SPLIT].
2. Select a voice for the right hand.
Use the voice group buttons and VARIATION [▼][▲] to select the voice for the right-hand area.
3. Select a voice for the left hand.
Hold down [SPLIT], and press a voice group button to select the voice group for the left-hand area.
Use C [-][+] to select a voice.

TIP

You can also use A [-][+] to select a voice for the right-hand area.

TIP

Refer to page 26 for details on how to select XG voice.

4. Specify the split point (the border between the right- and left-hand range).

The normal setting of the split point is “F#2.”

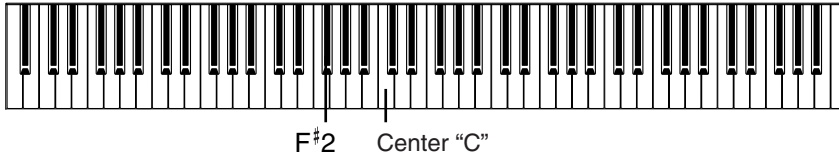

To change the split point setting:

Hold down [SPLIT], then use the D [-]/[+] to specify the split point.

(Optional) Press and hold down the [SPLIT] and play the key you wish to assign as the split point.



Release the [SPLIT] button to return to the main screen.

5. Exit Split mode and return to normal play mode.
Press [SPLIT].

You can use Dual (see page 30) in each area (right-hand and left-hand) of Split mode.



TIP

A specified “split point” key is included in the left-hand range.

TIP

The split point can also be set by the [OTHER SETTING] parameter [Split-Point]. (page 69)

Using the metronome

The PF-500 is built-in metronome (a device that keeps an accurate tempo) is a convenient feature for practice.

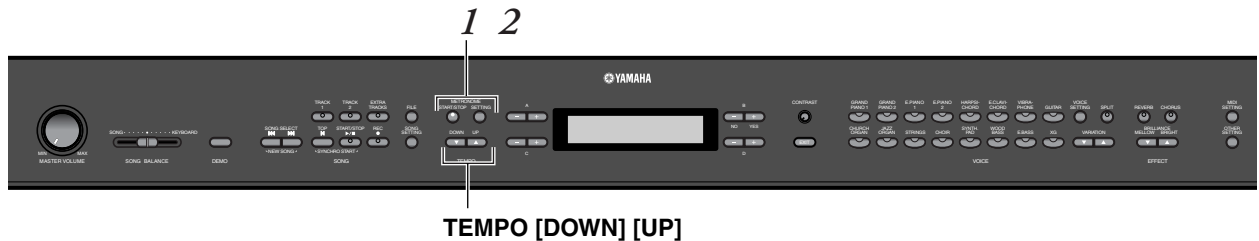

Procedure

1. **Start the metronome.**
Press the **METRONOME [START/STOP]** button.

When the metronome is sounding, the beat indicator flashes at the current tempo.

Adjusting the tempo

Press the TEMPO [DOWN] or [UP] button.

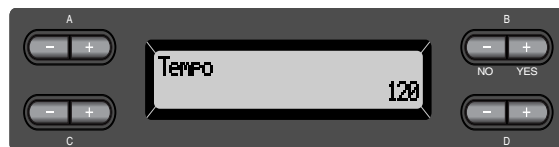

To adjust the tempo (number of beats per minute: 10–500), use the TEMPO [DOWN]/[UP] or the D [-]/[+] buttons. To reset the tempo to the normal (default) setting, press the [DOWN] and [UP] keys or the D [-] and [+] keys simultaneously.

Press the [EXIT] button to return to the normal screen.

2. **Stop the metronome.**
Press the **METRONOME [START/STOP]** button.

TIP

The default tempo is 120. (If a song has been selected, the song tempo is used.)

TIP

You can set the time signature, metronome volume, and metronome tone using the METRONOME [SETTING] button. (See page 68.)

Recording Your Performance

This chapter explains how to record your performance using the PF-500 recording function.

You can, for example, play back what you have played on the PF-500 keyboard for an effective practice aid. You can also record just the left-hand part, then practice the right-hand part while playing back the recorded left-hand part. Since you can record up to sixteen tracks separately, you could record the left- and right-hand parts separately, or record each part of a four-handed performance or ensemble song one by one to build a song.

TIP

You can record your performance (audio data) to a cassette tape recorder or other recording devices via the AUX OUT connector. (see page 52.)

TERMINOLOGY

Recording vs. Saving:

The format of performance data recorded on a cassette tape differs from that of data recorded on the PF-500. A cassette tape records audio signals. On the other hand, the PF-500 “saves” information regarding note timing, voices, and a tempo value, but not audio signals. When you play back recorded songs, the PF-500 produces sound based on the saved information. Therefore, recording on the PF-500 may be more accurately called “saving information.” However, this book often uses the word “recording” because it seems to make more sense.

A message (information or confirmation dialog) sometimes appears on the screen to facilitate operation. Refer to the “Message List” on page 86 for an explanation of each message, appropriate actions to take, and troubleshooting information.

Recording a New Song

Recording to [TRACK 1]



Procedure

1. Select “NewSong” for recording.
Press the SONG SELECT [◀◀] [▶▶] buttons simultaneously.

New Song screen



NOTE

If you select a song other than “P-000: NewSong” and record on a track that already has data, the existing data on the track will be lost.

2. Select a voice.

Select a voice (or voices) for recording (see page 26).

Set the other parameters, such as reverb and chorus.

Adjust the [MASTER VOLUME] dial to set the volume level to suit your preference. You can also use the dial to adjust the level during playback.

After you set the tempo or if the record standby screen does not appear, press one of the SONG SELECT [◀◀] [▶▶] buttons once to return to the New Song screen.

3. Enter record mode and select a recording track.

Press and hold down the [REC] button and press the [TRACK 1] button.

The [TRACK 1] indicator flashes in red. (To cancel recording, press the [REC] or [TOP] button.)

Record standby screen



Set the tempo, if necessary.

If this record standby screen does not appear, press one of the SONG SELECT [◀◀] [▶▶] buttons once.

4. Start and stop recording.

Recording begins automatically as soon as you play a note on the keyboard.

(Optional) Press the SONG [START/STOP] button to start recording. The recording screen displays the current measure number.

Record screen



Measure number in recording

To stop recording, press the [TOP] button. The PF-500 locates the top of the song.

The [TRACK 1] indicator lights up in green. (Record mode is automatically cancelled.)

NOTE

Set the tempo in Step 3.

NOTE

See page 42 for more information on recording in Dual/Split mode.

TIP

You can record data while using the metronome. The metronome is not recorded.

TIP

When you press the SONG [START/STOP] button during recording, recording is paused. To resume recording, press the SONG [START/STOP] button again or play a note on the keyboard.

TIP

When you press the [REC] button, recording pauses.

- 5. Play back the recorded performance.**
Press the SONG [START/STOP] button to play back the recorded performance.

When playback is complete, it automatically stops and the PF-500 locates the top of the song. To stop playback in the middle of a song, press the [TOP] button. You can also pause playback by pressing the SONG [START/STOP] button. Playback stops when you press the button.

When you turn off the power to the PF-500, the recorded performance data will be lost. If you wish to keep the recording, save the data using the SaveToMemory parameter (page 45) in the File menu.

NOTE

To erase recorded data from a track, use the Channel Clear parameter in the "SONG SETTING" menu. (See page 66.)

Re-recording TRACK 1

This section explains how to record again in case your performance was not satisfactory.

Procedure

- 1. Select a voice or voices for recording, if necessary.**
Repeat Step 2 on page 36 if you wish to change the previous settings.

Follow the procedure from Step 3 on page 36 to re-record.

The original performance data will be overwritten by new performance data.

Re-recording TRACK 1 partially

This section explains how to record part of a song again.

Procedure

1. Pause the song at the beginning of the part you wish to re-record.

Use the B [-]/[+] buttons while the playback screen is displayed to move through the measures or play back the recording and press the SONG [START/STOP] button to locate a point slightly prior to the beginning of the part you wish to re-record.

Playback screen



2. Select a voice or voices for recording, if necessary. Repeat Step 2 on page 36 if you wish to change the previous settings.
3. Select the recording method and enter record mode.
- 3-1 Press and hold down the [REC] button, and press the C [-]/[+] buttons repeatedly to specify how the recording should start and press the D [-]/[+] buttons repeatedly to specify how the recording should end.

While you are holding down the [REC] button, the following recording method select screen appears.



Starting methods:

Norm (Normal) — The existing data will be erased after re-recording starts.

Key On — Data that exists prior to the point where you start playing a note will not be erased.

NOTE

If the playback screen is not displayed, press one of the SONG SELECT [◀◀] [▶▶] buttons once.

NOTE

When the starting method is set to "KeyOn," you cannot change a voice or tempo (page 41) after the recording is complete.

Ending methods:

Replace – The data after the point you stop recording will also be erased.

Punch Out — The data after the point you stop recording will remain.

3-2 Keep holding down the [REC] button and press the [TRACK 1] button.

The [TRACK 1] indicator flashes in red.

(To stop recording, press the [REC] button again or press the [TOP] button.)

Follow the procedure beginning with Step 4 on page 36.

TIP

If you cancel recording by pressing the [REC] button, recording stops when you press the button. If you cancel recording by pressing the [TOP] button, the PF-500 locates the top of the song.

Recording to [TRACK2]

This section explains how to record another part on the second track.

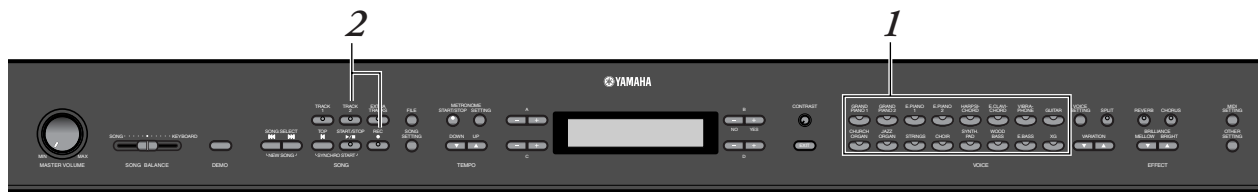

Procedure

1. Select a voice.
Select a voice (or voices) for recording.
Repeat Step 2 on page 36.
2. Enter record mode and select a recording track.
Press and hold down the [REC] button and press the [TRACK 2] button.

The [TRACK 2] indicator flashes in red. (To cancel recording, press the [REC] or [TOP] button.)

TIP

Pressing the [TRACK 1] button repeatedly toggles between playback on (the indicator lights up in green) and off (the indicator turns off).

Make the recording by following the procedure beginning with Step 4 on page 36.

You can record a new part while listening to playback of the recorded [TRACK 1] data.

Recording to the third or more tracks [EXTRA TRACKS]

You can continue recording other parts into tracks 3–16 [EXTRA TRACKS] one by one.

Procedure

1. Hold down the [REC] button in step 2 in the “Recording to [TRACK2]” on page 39 and use the B [-]/[+] buttons to select a recording track (3–16).

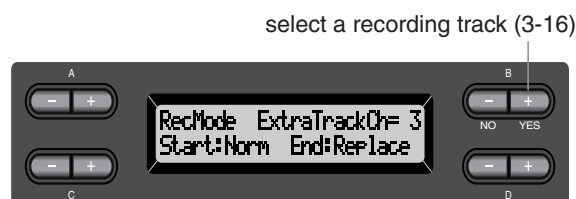

2. While holding down the [REC] key, press the [EXTRA TRACKS] button.

Then, follow the procedure beginning with Step 4 on page 36.

Other recording techniques

Adding data to or recording over an existing song

The previous section explains how to record your performance from the beginning by selecting a blank “P-000: NewSong.” You can also add your performance to or overwrite existing songs (such as 50 preset piano songs [P-001—P-050], or your old recorded performances [see page 43]).

Procedure

1. **Select a song for recording (P-001 – P-050).**
Select one of the preset songs (P-001–P-050) instead of “P-000: NewSong” as described in Step 1 of “Recording to [TRACK1]” on page 35. To select a song from already-recorded data, see Steps 1 and 2 on page 48.

NOTE

If you record on a track that already has data, the existing data on the track will be lost.

To continue recording, follow the procedure described in “Recording a New Song” from page 35 to 40.

Changing a voice or tempo after recording

You can change the voice and tempo after recording to change a song's feel or to set a more suitable tempo. You can also change these elements in the middle of a song.

Procedure

1. Select a song you wish to change by using the SONG SELECT [◀◀] [▶▶] buttons.

2. To change the voice or tempo in the middle of the song, specify the measure to change using the B [-]/[+] buttons.

3. Change the settings (voice, reverb, etc.).
For example, if you wish to change the recorded E.Piano1 voice to E.Piano2, use the voice group buttons and the A [-]/[+] buttons to select E.Piano2.

When the setting is complete, press one of the SONG SELECT [◀◀] [▶▶] buttons once to return to the song select screen.

4. Press and hold down the [REC] button and select the track to change.

The indicator for the selected track lights up in red. Change the tempo setting now, if necessary.

At this point, do not play the keyboard or press the SONG [START/STOP] button. Otherwise, recording will start, erasing the recorded data.

5. Press the [TOP] or [REC] button to exit record mode.

NOTE

When the starting method is set to "KeyOn," you cannot change a voice or tempo (page 38) after the recording is complete.

TIP

Refer to "Questions about Operations and Functions" on page 90 for information on the settings that can be changed here.

TIP

Change the tempo in Step 4.

⚠ CAUTION

The edited settings (except for the tempo setting) will be saved in memory and you will not be able to restore the previous settings. Proceed with caution.

Adjusting the volume balance between playback and your performance [SONG BALANCE]

While recording multiple parts into tracks one by one, you can adjust the volume balance between the playback of the recorded parts and your current performance.

Procedure

1. Move [SONG BALANCE] to the left or right to make adjustments.

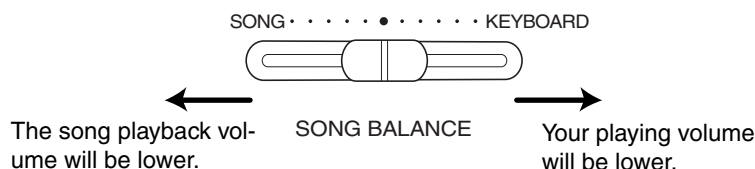

TIP

The song balance setting is also used during playback. (See page 48.)

Recording in Dual or Split mode

When you record in Dual or Split mode, the PF-500 records each voice onto a separate track. The following table shows how tracks are assigned to each voice.

⚠ CAUTION

When you record multiple parts into tracks one by one, or when you record new data over an existing song (see page 40), the existing data will be erased. Proceed with caution.

In the following example, Tracks 1, 2, and EXTRA TRACKn have been selected for recording.

Tracks assigned for recording	Dual			Split			Split+Dual		
	TRACK1	TRACK2	EXTRA TRACKn	TRACK1	TRACK2	EXTRA TRACKn	TRACK1	TRACK2	EXTRA TRACKn
	↓	↓	↓	↓	↓	↓	↓	↓	↓
Tracks used for recording	MAIN (voice 1)	TRACK1	TRACK2	TRACKn	TRACK1	TRACKn	TRACK1	TRACKn	
	LEFT (voice 1)	—			TRACK2	TRACKn+1	TRACK2	TRACKn +1	
	MAIN (voice 2)	TRACK3	TRACK4	TRACKn +2	—			TRACK3	TRACKn +2
	LEFT (voice 2)	—			—			TRACK4	TRACKn +3

Note: TRACKn = TRACK 3 – TRACK 16
If “n+1,” “n+2,” and “n+3” exceed 16, TRACKs 1, 2, and 3 are used.

TIP

Switching between Dual and Split mode in a song is not recorded.

Saving Recorded Songs and Handling the Files...[FILE]

File screens (accessed via the [FILE] button) enables you to handle song files (e.g., save, delete, and rename recorded songs), and change the characters on the screen.

The following parameters are provided for these operations:

Settings	Parameter name	Reference page
Saves recorded and other songs in PF-500 memory	SaveToMemory	45
Deletes a song from PF-500 memory	DeleteSong	46
Changes the title of songs	RenameSongs	47
Change the type of characters on the screen	CharCode	47

PF-500 memory

The PF-500 has the following three types of memory:

- **Current memory:**
This is a temporary memory area where you can temporarily place and edit the currently-selected song before playback or recording.
- **Preset song memory:**
This read-only memory area saves 50 piano preset songs.
- **Storage memory:**
This memory area enables you to save recorded songs.

When you select a song in the song select screen, it is loaded from Preset song memory or Storage memory into Current memory.

You will use Current memory to play back and record songs. When you turn off the power to the PF-500, songs saved in Preset song memory and Storage memory are not erased. On the other hand, songs in Current memory are lost. If you wish to keep a song in Current memory, you must save it in Storage memory (see pages 45).

In this manual, a song located in a song recorded in Current memory, is referred to as a “**Current song**” and a song in Storage memory is a “**Memory song**.”

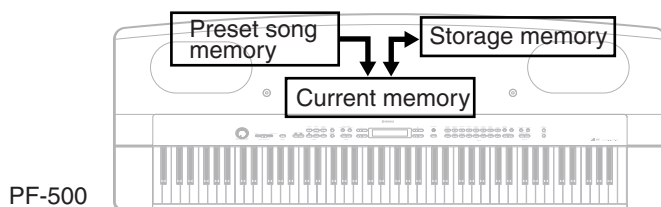

PF-500

TERMINOLOGY

File

A file contains a group of data. On the PF-500, a song file includes song data and a song number.

Memory

Memory is a location inside the PF-500 in which you can save and edit data.

Character code

Type of characters

Basic file operation

A message (information or confirmation dialog) sometimes appears on the screen to facilitate operation. Refer to the “Message List” on page 86 for an explanation of each message, appropriate actions to take.

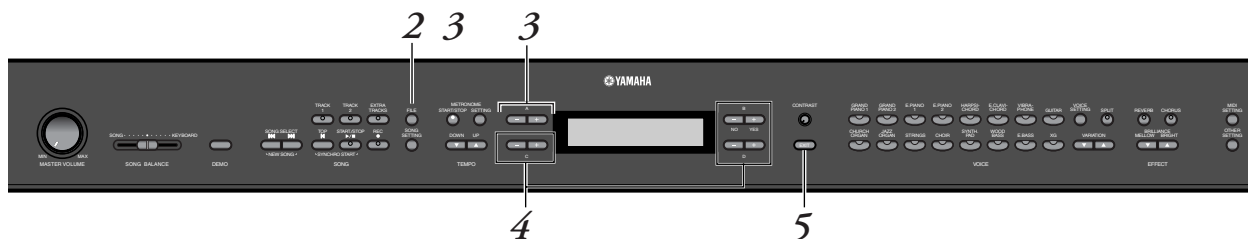

Procedure

- 1. Select a song.**
Select a song you wish to save or rename.
- 2. Access the File menu.**
Press the [FILE] button.



To close the File menu, press the [EXIT] button once or twice.

- 3. Select the desired parameter.**
Press the [FILE] or A [-]/[+] buttons repeatedly to display the desired item from the following:
“SaveToMemory”, “DeleteSong”, “RenameSong”, “CharacterCode”.
- 4. Set the parameter or execute the command.**
Use the B [- (NO)]/[+ (YES)], C [-]/[+], D [-]/[+] buttons.
For more information regarding this procedure, refer to the corresponding section below.
- 5. Close the File menu.**
Press the [EXIT] button.

Saving recorded or other songs to PF-500 Storage memory...[SaveToMemory]

If you record a song, then turn off the power to the PF-500, the song will be erased. To save the recorded song, you must save it into the PF-500 Storage memory. You can also save the preset songs, and additional or overwriting recordings (page 40) to Storage memory.



Procedure

See page 44 the basic operation information. The following is a detailed procedure of Step 4.

4-1 Name the song.

- To move the cursor (a small underline), use the C [-]/[+] buttons.
- To insert a space, press the C [-]/[+] buttons simultaneously.
- To select a character on the cursor, use the D [-]/[+] buttons.
- To delete a character, press the D [-]/[+] buttons simultaneously.

You can use up to 58 characters for a song name. If the name is longer than the screen, use the C [-]/[+] buttons to move the cursor and scroll the name.

4-2 Execute the operation.

- Press the B [+ (YES)] button located next to “Execute?->”.
- “Sure?->” appears on the screen. Press the B [+ (YES)] button again to confirm the operation. (To cancel the operation, press the B [- (NO)] button.)
- The PF-500 displays “Executing” on the screen during the operation.
- When the operation is complete, “Completed” appears.
- The song is automatically numbered as “M—,” where “M” means “Memory” and “—” is a number.

TIP

If Storage memory contains one or more songs, and you save a new song, the PF-500 automatically sorts the songs alphabetically and rennumbers them.

TIP

- You can change the type of characters on the screen using the CharacterCode parameter.
- When you select a saved song later, the name with an extension “.MID” will appear.

TERMINOLOGY

“Execute?->”: Do you wish to execute the operation?

“Sure?->”: Are you sure?

“Executing”: The PF-500 is executing the operation.

“Completed”: The operation is complete.

CAUTION

Do not turn off the power while the screen displays “Executing.”

Deleting a Memory song...[DeleteSong]

This deletes a song from memory. You cannot delete a preset song or the current song.



Procedure

See page 44 for basic operation information. The following is a detailed procedure of Step 4.

4-1 Select a song to delete.

Use the C [-]/[+] buttons to select a song.

4-2 Execute the operation.

Press the B [+ (YES)] button located next to "Execute?->."
Follow the instructions on screen.

TIP

To delete a Current song, select "ALL" for the Channel-Clear parameter in the "SONG SETTING" menu (page 66). Alternatively, press the SONG SELECT [◀◀]/[▶▶] buttons simultaneously to display "Song Changed Save?". This means "A song has been edited. Do you wish to save the change?" Press the B [- (NO)] button. The Current song is deleted and a blank "NewSong" is selected.

TIP

Deleting a Memory song does not erase song data from Current memory. However, if you return to the song select screen, song information other than the song name is replaced by "-----".

TIP

After you delete a song, the PF-500 automatically updates the song numbers.

⚠ CAUTION

Never turn off the power while [Executing] is displayed.

Renaming a song...[RenameSong]

You can change a song's title except for the preset songs and [P-000: NewSong].



Procedure

See page 44 for basic operation information. The following is a detailed procedure for Step 4.

4. Name the song as described in the [SaveToMemory] section (page 45).

CAUTION

Do not turn off the power while the screen displays "Executing."

TIP

After you rename a song, the PF-500 sorts songs alphabetically and renumbers them.

Changing the type of characters on screen...[CharacterCode]

You can change the type of characters that appear on screen.

The default setting is "International." To input katakana, change this setting to "Japanese."



Options: International, Japanese

Character list

[International]

0~9	A~Z	a~z	Ä	Ë	Ï	Ö	Ü	ä	ë	ï	ö	ü	à	è	ì	ò	ù	á	é	í	ó	ú	â	ê	î	ô	û	Ñ	ñ	ß	Ç	ç	°	ı	ı	!	#	\$	%	&	'	()
+	,	-	.	;	=	@	[]	^	_	`	{	}	~																													

[Japanese]

0~9	A~Z	a~z	ア	ン	ア	オ	ヤ	ユ	ヨ	ツ	ッ	°	-	。	「	」	,	・	!	#	\$	%	&	'	()	+	,	-	.	;	=	@	[]	^	_	`	{	}	~
-----	-----	-----	---	---	---	---	---	---	---	---	---	---	---	---	---	---	---	---	---	---	----	---	---	---	---	---	---	---	---	---	---	---	---	---	---	---	---	---	---	---	---

Playing Back Recorded Songs

You can play back songs recorded using the Record function (page 35). You can also play the keyboard along with the playback.

TIP

Songs containing a large amount of data may not be able to be read properly by the instrument, and as such you may not be able to select them. The maximum capacity is about 200–300KB, however this may differ depending on the data contents of each song.

TIP

Change the PF-500's character type ([Character-Cord]) as appropriate for the selected song.

Playing back a song

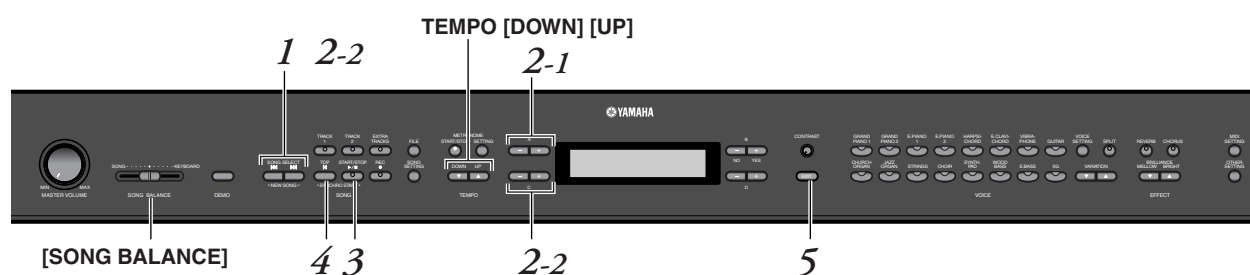

Procedure

1. Display the song select screen.
Press either the **SONG SELECT** [**◀**]/[**▶**] buttons.

Song select screen



2. Select the desired song.
- 2-1 Use the **A** [**-**]/[**+**] buttons to select the song type: "PresetSong" or "MemorySong."
If the internal Storage memory contains one or more songs, the PF-500 displays "MemorySong."
- 2-2 Use the **C** [**-**]/[**+**] or **SONG SELECT** [**◀**]/[**▶**] buttons to select a song.

TIP

You can enjoy ensemble performance by yourself. Record the parts for a four-handed song or a piano duet, then play the recorded part while playing the other part on the keyboard.

TIP

Use the SongRepeat parameter in the "SONG SETTING" menu (page 67) to select repeat playback of all songs or repeat playback of a single song.

TIP

If the song name extends beyond what can be displayed in the screen, you can press **D** [**+**] to move toward the right in steps of one character. Press **D** [**-**] to move back to the left in steps of one character.

3. Start playback.

Press the SONG [START/STOP] button.

Starting playback automatically as you start playing the keyboard (Synchro Start)

You can start playback as soon as you start playing the keyboard. This is called the “Synchro Start” function.

To enter Synchro Start standby mode, press and hold down the [TOP] button and press the SONG [START/STOP] button. The SONG [START/STOP] indicator flashes.

Now play the keyboard. Playback starts simultaneously.

To cancel the Synchro Start function, press the [TOP] button while the PF-500 is in Synchro Start standby mode.

You can move back and forth (rewind and fast forward) through the bars by using the B [-]/[+] buttons in the song select screen while the PF-500 is playing or stopped.

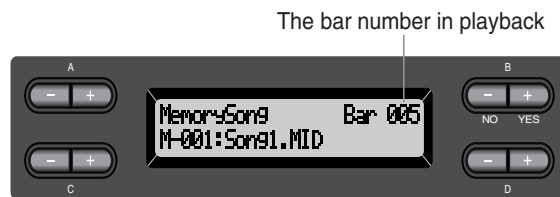

You can play the keyboard while the PF-500 is playing back a song. You can also play the notes in a voice different from the playback voice by selecting the voice from the panel, and adjusting the volume balance between the playback parts and your current performance using the [SONG BALANCE] slider. (See page 42.)

Press either of the SONG SELECT [◀◀]/[▶▶] buttons to return to the song select screen.

Adjusting the tempo

You can use the TEMPO [DOWN]/[UP] buttons to adjust the playback tempo as required before or during playback. The default tempo (the song’s original tempo) is set when you press the [DOWN] and [UP] buttons simultaneously.

Press either of the SONG SELECT [◀◀]/[▶▶] buttons to return to the song select screen.

4. Stop playback.

When playback is complete, the PF-500 automatically stops and locates the top of the song. To stop playback in the middle of a song, press the [TOP] button. You can also pause playback by pressing the SONG [START/STOP] button. Playback stops when you press the button.

5. Return to the main screen.

Press the [EXIT] button.

TERMINOLOGY

Bar: measure

TIP

You can play the metronome along with the song playback. When you stop playback, the metronome is also stopped.

TIP

In the song select screen:

- Press the SONG SELECT [◀◀] or the C[-] button while playback is stopped in the middle of the song to locate the top of the song.
- Press the SONG SELECT [◀◀] or the C[-] button during playback to restart playback from the top of the song.
- Press the SONG SELECT [▶▶] or the C[+] button during playback to start playback from the next song.

Turning track playback on and off

When you select a song on the PF-500, the indicators for tracks that contain data ([TRACK 1], [TRACK 2], [EXTRA TRACKS]) are lit in green. While the PF-500 is playing or stopped, pressing these track buttons turn off the indicators, and the data on those tracks will not be played. Pressing the track buttons toggles track playback on and off. You can play the part that is turned off.

TIP

You can practice a part or phrase using the FromToRepeat (page 66) and Phrase-Mark parameters (page 67) in the “SONG SETTING” menu.

Supported song data type

Data formats that can be played on the PF-500

The PF-500 plays song data in the following formats:

Sequence format

- SMF (Standard MIDI File) formats 0 and 1
- ESEQ

Voice arrangement format

- XG voice arrangement
- GM system level 1 voice arrangement
- DOC voice arrangement

See page 6 of the separate “Reference Booklet” for the XG voice list. Refer to “Data compatibility” on page 95 for more information on formats.

TERMINOLOGY

Sequence format:

A structured method for recording performance data.

TERMINOLOGY

Voice arrangement format:

A structured method for numbering the voices for assignment.

Connections

Connectors

⚠ CAUTION

Before connecting the PF-500 to other electronic components, turn off the power to all the components. Before turning the power on or off to all components, set all volume levels to minimum (0). Otherwise, electrical shock or damage to the components may occur.

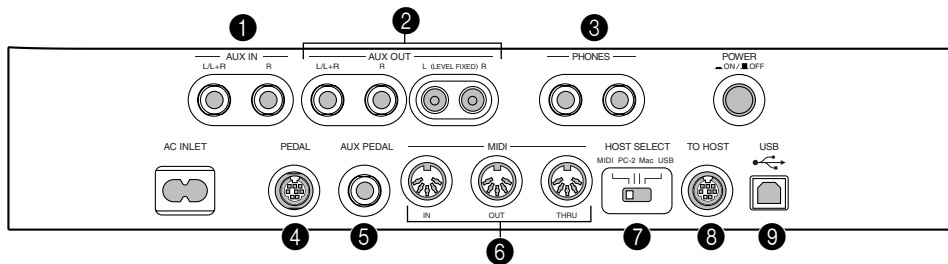

① AUX IN [R], [L/L+R] jacks

The stereo outputs from another instrument can be connected to these jacks, allowing the sound of an external instrument to be reproduced via the PF-500's speakers. Refer to the diagram below and use audio cables for connection.

⚠ CAUTION

When the PF-500's AUX IN jacks are connected to an external device, first turn on the power to the external device, then to the PF-500. Reverse this order when you turn the power off.

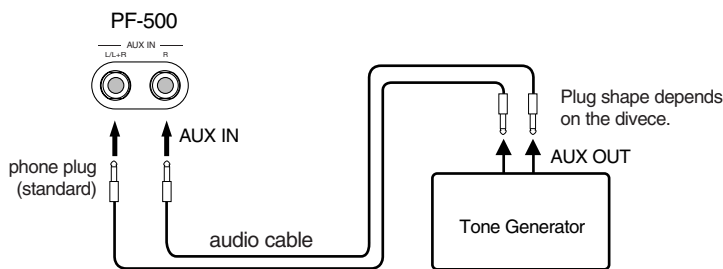

TIP

The PF-500's [MASTER VOLUME] dial setting affects the input signal from the AUX IN jacks, but the [REVERB], [CHORUS], and BRILLIANCE [MELLOW] [BRIGHT] (page 28) settings do not.

TIP

If you connect the PF-500 to a monaural device, use only the AUX IN [L/L+R] jack or AUX OUT [L/L+R] jack.

2 AUX OUT [R][L] Pin jacks (LEVEL FIXED), [R][L/L+R] Phone jacks

These jacks let you connect the PF-500 to your stereo system etc. to play at higher volumes, or connect a cassette recorder etc. to record your playing. Use audio cables to make connections as shown in the diagram.

⚠ CAUTION

When the PF-500's AUX OUT jacks are connected to an external audio system, first turn on the power to the PF-500, then to the external audio system. Reverse this order when you turn the power off.

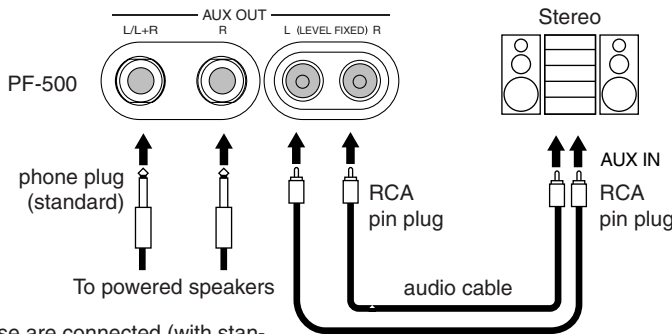

When these are connected (with standard phone plugs), you can use the [MASTER VOLUME] control to adjust the volume of the sound output to the external device.

When these are connected (with RCA pin plug; LEVEL FIXED), the sound is output to the external device at a fixed level, regardless of the [MASTER VOLUME] control setting.

3 PHONES jack

See page 16.

4 PEDAL jack

See page 14.

5 AUX PEDAL jack

A separately sold FC7 foot controller or FC4/FC5 foot switch can be connected to this jack. By using an FC7 you can control the volume while playing to add expression to your performance, or control various other functions. By using an FC4/FC5, you can switch various selected functions on/off. To select the function that will be controlled, use the [VOICE SETTING] parameter [AuxPedal] (See page 76). The SONG [START/STOP] function can also be assigned to a foot switch (See page 84).

6 MIDI [IN], [OUT], [THRU] connectors

Use MIDI cables to connect external MIDI devices to these connectors. Make sure you set the HOST SELECT switch (described on the previous page) to MIDI when you use these connectors.

7 HOST SELECT switch

This switch should be set according to the type of connected MIDI device or personal computer. (Refer to “Connecting a personal computer” on page 53 for more information.)

8 TO HOST jack

This jack allows direct connection to a personal computer. (Refer to “Connecting a personal computer” on page 53 for more information.)

9 USB jack

This jack allows direct connection to a personal computer. (Refer to “Connecting a personal computer” on page 53 for more information.)

⚠ CAUTION

Do not route the output from the AUX OUT jacks to the AUX IN jacks. That is, when you connect an external audio device to the AUX OUT jacks, do not connect the audio device to the PF-500's AUX IN jacks. If you make this connection, the signal input at the AUX IN jacks will be output from AUX OUT. This creates an audio loop, causing audio oscillation and abnormal playback, and leading to malfunction of both pieces of equipment.

TIP

Use audio cables and adaptor plugs with no resistance.

TIP

The PF-500's [MASTER VOLUME] setting will not affect the sound that is output from AUX OUT (LEVEL FIXED).

TIP

Connect or disconnect the pedal when the power is off.

Connecting a personal computer

You can connect the [TO HOST], MIDI [IN][OUT][THRU], or [USB] connector of the PF-500 to your personal computer and enjoy using the PF-500 in conjunction with musical software on your computer.

There are the three methods by which to connect the PF-500 to a personal computer:

1. Connecting the serial port on the computer to the PF-500's TO HOST jack (page 52)
2. Using a MIDI interface and the PF-500's MIDI connectors (page 52)
3. Connecting the USB port on the computer to the PF-500's USB jack (page 52)

For more information, refer to the following pages.

TIP

When connecting the PF-500 to a personal computer, first turn off the power to both the PF-500 and the computer before connecting any cables and setting the HOST SELECT switch. After making connections and switch settings, turn on the power to the computer first, then to the PF-500.

TIP

If you are not using the connection between the PF-500 and your computer, you must disconnect the cable from the [TO HOST] jack or [USB] jack. The PF-500 may not operate correctly if a cable is left connected.

TIP

The connectors that can be used will depend on the setting of the HOST SELECT switch.

HOST SELECT switch setting	Usable connectors
[MIDI]	[MIDI] connectors (all: [IN][OUT][THRU])
[PC-2], [Mac]	[TO HOST] jack
[USB]	[USB] jack

1. Connecting the serial port on the computer to the PF-500's TO HOST jack

Connect the computer's serial port (RS-232C or RS-422) to the PF-500's TO HOST jack.

In this connection, the PF-500 functions as a MIDI interface. Therefore, you do not need a special MIDI interface.

Connection

Use a special serial cable (page 55) to connect the computer's serial port (RS-232C or RS-422) to the PF-500's TO HOST jack.

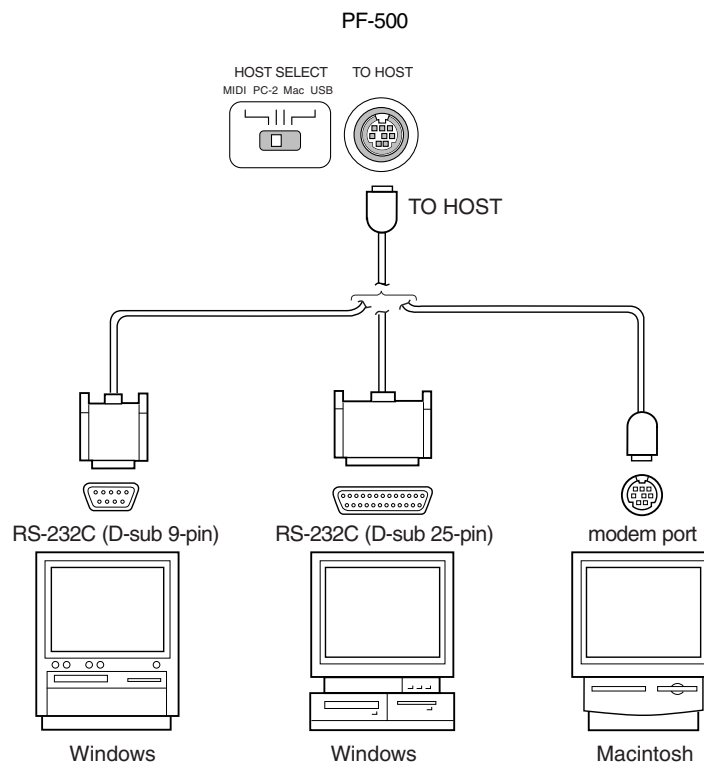

Note for Windows users (regarding the MIDI driver)

To transfer data via the computer's serial port and the PF-500's TO HOST jack, you need to install a specific MIDI driver (the Yamaha CBX driver for Windows). You can download this driver from XG Library on the Yamaha Web site (<http://www.yamaha-xg.com>) or install from the Accessory CD-ROM included with the PF-500.

Type of serial cables and connection pin assignments

According to the type of computer you connect, use one of the following serial cables.

- **Windows (with a serial port of D-sub 9-pin)**

8-pin mini DIN plug → D-sub 9-pin plug
(Yamaha CCJ-PC2 or equivalent)

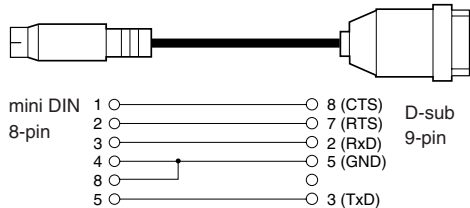

- **Macintosh**

System peripheral plug → 8-pin plug
(Yamaha CCJ-MAC or equivalent)

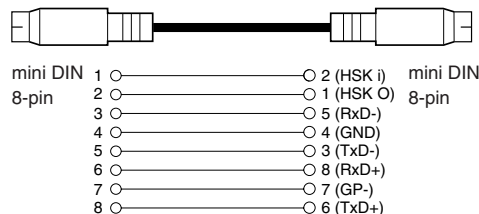

- **Windows (with a serial port of D-sub 25-pin)**

8-pin mini DIN plug → D-sub 25-pin plug
(Yamaha CCJ-PC1NF or equivalent)

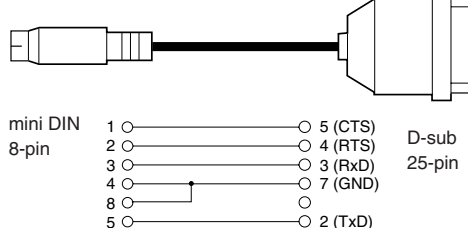

- **Pin assignment**

The following diagram shows the pin assignments for each cable.

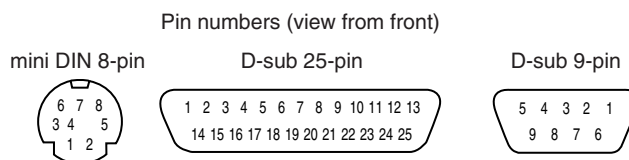

PF-500 HOST SELECT switch setting

Set the PF-500 HOST SELECT switch properly according to the type of connected computer.

- **Macintosh:** “Mac” (data transfer rate: 31,250bps, 1MHz clock)
- **Windows:** “PC-2” (data transfer rate: 38,400bps)

TIP

If your system does not work properly with the connections and settings listed above, your software may require different settings. Check your software operation manual and set the HOST SELECT switch to the proper data transfer rate.

2. Using a MIDI interface and the PF-500's MIDI connectors

Connection

Use a MIDI interface device to connect a computer to the PF-500 using special MIDI cables.

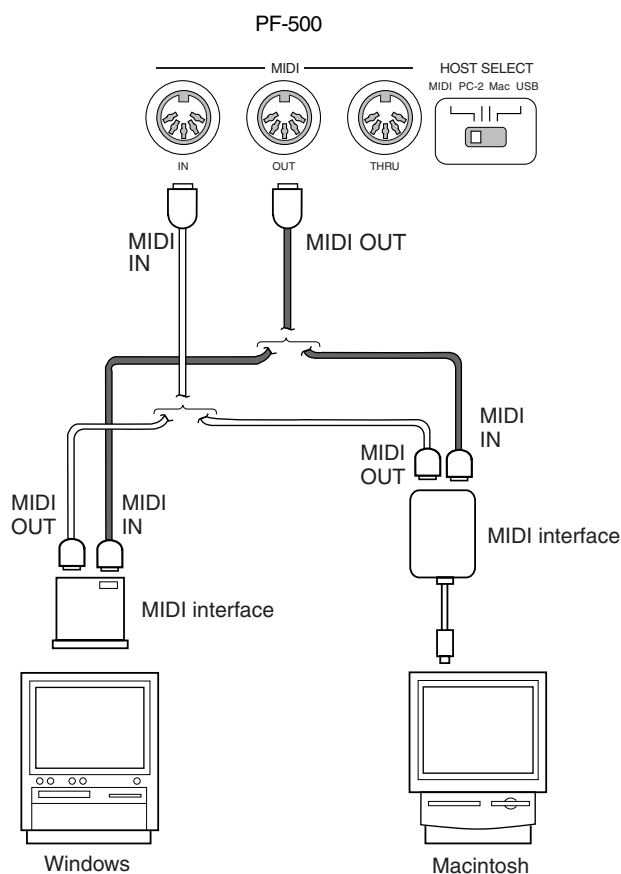

PF-500 HOST SELECT switch setting

Set the PF-500 HOST SELECT switch to "MIDI."

3. Connecting the USB port on the computer to the PF-500's USB jack

If you connect the PF-500 to your computer, you can transfer MIDI data between your computer and the PF-500. You can also use the included File Utility (software for your computer) to transfer files between your computer and the internal memory of the PF-500.

Connections

Use a USB cable to connect the USB port on your computer to the [USB] jack on the PF-500.

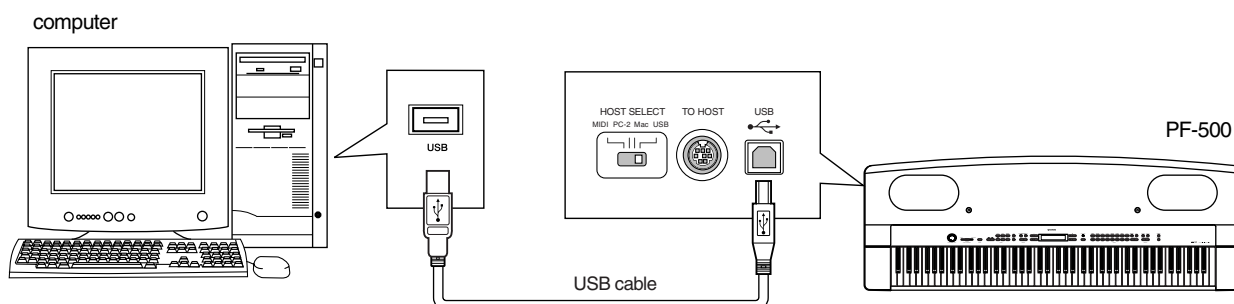

TIP

There are two types of USB connectors: A and B. The USB jack on the PF-500 accepts a B-type connector. Connect the A-type connector of the USB cable to the USB port on your computer. Connect the B-type connector to the USB jack on the PF-500.

PF-500 HOST SELECT switch setting

Set the PF-500 HOST SELECT switch to "USB."

About the USB driver

You must install the specified USB driver (YAMAHA USB MIDI Driver) in your computer before you can transfer data between the computer and the PF-500.

The YAMAHA USB MIDI Driver can be installed from the Accessory CD-ROM included with the PF-500.

The YAMAHA USB MIDI Driver supports the following OS versions.

Windows 98, Windows 98SE, Windows Me, Windows 2000, Windows XP

Mac OS 8.6–9.2.1

About the USB connector

- In order to use MIDI on your computer, you will need application software that is appropriate for your computer and that meets your needs.
- If you want to use a USB cable to connect the PF-500 to your computer, you must connect the USB cable before turning on the power of the PF-500.
Also, do not turn the power of the PF-500 on or off while application software that uses USB MIDI is running.
- The PF-500 will begin transmission a short time after the USB connection is made.
- If you are using Windows 2000, problems may occur on your computer when your computer starts up. In this case, turn on the power of the PF-500 when your computer is running.
- When using a USB cable to connect the PF-500 to your computer, make the connection directly without passing through a USB hub.
- Depending on the state of your computer, the operating state of the PF-500 may become unstable. Do not use your computer in a way that causes it to enter an unstable state.

CAUTION

- If you turn the power of the PF-500 on/off or connect/disconnect the USB cable in the following states, problems will occur in the computer system, possibly causing it to “freeze” (hang up), or causing the PF-500 to stop functioning.
 - While installing the driver
 - While starting-up or shutting-down the operating system
 - While your computer is suspended (sleeping)
 - While a MIDI application is running
- Performing the following actions may cause your computer to hang up or the PF-500 to stop functioning.
 - Rapidly turning the power on/off or connecting/disconnecting the cable
 - Shifting to power-conservation (sleep) mode while MIDI data is being transferred, or returning from sleep mode
 - Connecting/disconnecting the cable while the power of the PF-500 is on
 - Turning the power of the PF-500 on/off, starting up your computer, or installing the driver while a large amount of data is being transferred

Detailed Settings

Detailed Settings

You can set various parameters to make the best use of PF-500 functions, such as fine tuning the pitch, selecting a voice for the metronome, repeating playback, etc. For the basic procedure to make these settings, refer to page 85.

Parameter List

The following parameters are available.

Recording and playback [SONG SETTING]

Settings	Parameter name	Reference page
Correcting note timing	Quantize	65
Specifying whether playback starts immediately along with the first voicing	QuickPlay	66
Auditioning the channels	ChannelListen	66
Deleting data by each channel	ChannelClear	66
Specifying the range and playing back repeatedly	FromToRepeat	66
Playing back the phrase specified by the phrase number	PhraseMark	67
Playing back a song repeatedly	SongRepeat	67

Metronome METRONOME [SETTING]

Settings	Parameter name	Reference page
Metronome time signature	TimeSignature	68
Metronome volume level	MetronomeVolume	68
Metronome voice	MetronomeSound	68

Voices [VOICE SETTING]

In Dual mode, parameters with the “*” mark are set for Voice 1 and Voice 2 individually.

Settings	Parameter name	Reference page
Octave*	Octave	70
Volume level*	Volume	70
Position of right and left channels*	Pan	70
Fine pitch adjustment (only in Dual mode)	Detune	70
Reverb type	ReverbType	71
Reverb depth*	ReverbSend	71
Chorus type	ChorusType	71
Chorus depth*	ChorusSend	71
Chorus on/off	ChorusOnOff	72
Select the DSP type*	DSP Type (DSP)	72
Set the speed of the vibraphone vibrato effect*	VibeRotorSpeed	72
Turn the vibraphone vibrato effect on/off*	VibeRotorOnOff (RotorOnOff)	73
Adjust the speed of the rotary speaker*	RotarySpeed (Rot.Speed)	73
Adjust the DSP effect depth*	DSPDepth	73
Adjust the brightness of the sound*	Brightness	73
Adjust the resonance effect*	HarmonicContent (Harmonic)	73
Adjust the low-range frequency of the equalizer*	EQ LowFreq. (EQ L.Freq)	74
Adjust the low-range gain (boost/cut) of the equalizer*	EQ LowGain	74
Adjust the high-range frequency of the equalizer*	EQ HighFreq. (EQ H.Freq)	74
Adjust the high-range gain (boost/cut) of the equalizer*	EQ HighGain	74
Touch sensitivity*	TouchSense	75
Right pedal function	RPedal	75
Center pedal function	MPedal	75
Left pedal function	LPedal	76
Auxiliary pedal function	AuxPedal	76

MIDI [MIDI SETTING]

Settings	Parameter name	Reference page
MIDI transmit channel	MidiOutChannel	78
Specify the MIDI receive channel	MidiInChannel	78
Local control on/off	LocalControl	79
Selecting performance from the keyboard or song data for MIDI transmission	MidiOutSelect	79
Type of data received via MIDI	ReceiveParameter	79
Type of data transmitted via MIDI	TransmitParameter	79
Song data bulk dump	SongBulkDump	80
Transmitting the initial settings	InitialSetup	80
Voice data bulk dump	VoiceBulkDump	80

[OTHER SETTING]

Settings	Parameter name	Reference page
Selecting a touch response	TouchResponse	81
Make fine pitch adjustments	Tune	81
Selecting a tuning curve for a piano voice	PianoTuningCurve	81
Selecting a scale	Scale	82
Specifying the Split Point	SplitPoint	82
Change the key	Transpose	82
Specify the depth of the Soft pedal	SoftPedalDepth	83
Depth of string resonance	StringResonanceDepth	83
Depth of sustain sampling for the damper pedal	SustainSamplingDepth	83
Specify the volume of the key-off sound	KeyOffSamplingDepth	83
Selecting a pedal function for vibraphone	VibraphonePedalMode	83
Assign the SONG [START/STOP] function to the pedal	PedalStart/Srop	84
Selecting a type of auxiliary pedal	AuxPedalType	84
Setting the point at which the damper pedal starts to affect the sound	HalfPedalPoint	84
Pitch bend range	PitchBendRange	84
Switch the speaker on/off	Speaker	85
Selecting the items saved at the time of shutdown	MemoryBackUp	85
Restoring the normal (default) settings	FactorySet	85

Making detailed settings

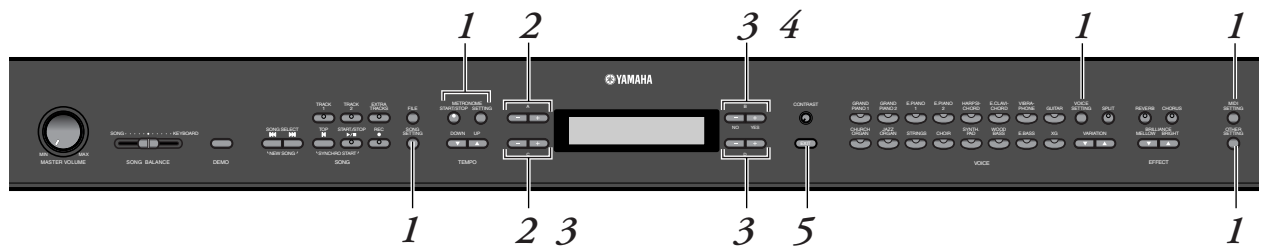

Procedure

1. **Access a setting menu.**
 Press the desired setting button ([SONG SETTING], [METRONOME [SETTING], [VOICE SETTING], [MIDI SETTING], or [OTHER SETTING]) to access the corresponding setting menu.

Press the [EXIT] button any time to close the setting menu.

2. **Select the desired parameter or part.**
 Press the setting button, A [-]/[+], and/or C [-]/[+] buttons repeatedly as required.

3. **Set the parameter or part.**
 Some parameters or parts lead you to more options. Use the B [- (NO)]/[+ (YES)], C [-]/[+], and D [-]/[+] buttons to select or set the option.

To restore the normal parameter value, press the [-] and [+] buttons simultaneously.

4. Write, execute, or save the data.

There are two ways to respond to the messages.

If “Execute?→” or “Start?→” appears:

Press the B [+ (YES)] button to display confirmation ([Sure?→]). To proceed, press the B [+ (YES)] button again. The PF-500 displays “Executing” and writes the data. When the operation is complete, it displays “Completed” for three seconds, then returns to the previous screen.

To cancel the operation, press the B [- (NO)] button instead of the B [+ (YES)] button.



If “Set?→” appears:

Press the B [+ (YES)] button to execute the setting. The PF-500 displays “Executing” and saves the data. When the operation is complete, it displays “Completed” for three seconds, then returns to the previous screen.

However, the “Completed” display that appears when [VoiceBulk-Dump] (page 80) is finished will not change back to the previous display after three seconds. Press any button on the panel to return to the previous display.

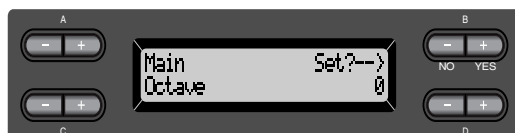

5. Close the setting menu.

Press the [EXIT] button.

Detailed settings for recording and playback [SONG SETTING]

You can make detailed settings for the selected song. First, select the desired song from preset songs (“Preset-Song”) or memory songs (“MemorySong”) (see page 48).

Procedure

Select the desired song and press the [SONG SETTING] button to access the “Song Setting” menu.

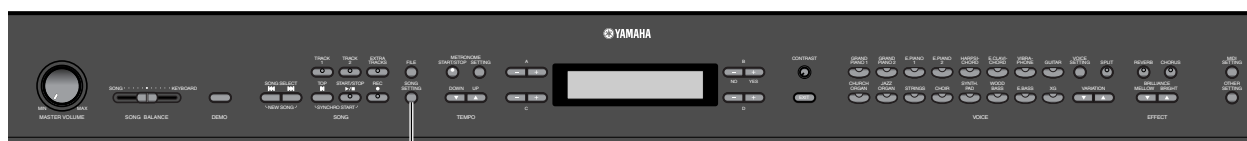

[SONG SETTING]

Correcting note timing [Quantize]

You can correct the timing of notes. For example, you can adjust recorded notes to precise eighth or sixteenth notes, or make the entire feel of a song more lively (with a swing type of rhythm).

- Changes are made by song.
- You can also listen to the sound while changing the setting. To change the data, you need to respond to “Execute?→.”

See the procedure on page 63.

Stores the changed value.

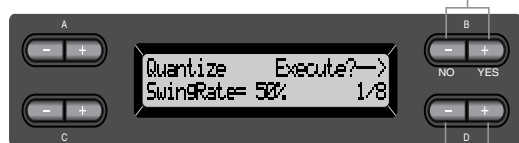

Specifies the type of note.

Notes for which you can adjust the timing:

[OFF]

[1/4] ♩ quarter note

[1/8] ♪ eighth note

[1/12] ♪♪♪ eighth note triplets

[1/16] ♫ sixteenth note

[1/24] ♫♪♪ sixteenth note triplets

If you select “1/8” or “1/16” for correction, the PF-500 displays “SwingRate=xx%”, which enables you to make the entire feel of a song more lively and swinging.

Setting range:

0% - 100%

If you select “1/8” for correction:

Performance data



Swing rate = 50% : not swinging

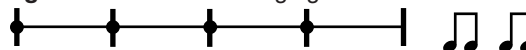

Swing rate = 75% (51% or higher) :

The timing of even beat notes is slightly delayed.

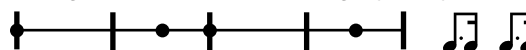

Swing rate = 25% (49% or lower) :

The timing of even beat notes is slightly early.

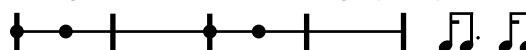

Swing rate = 67% :

The timing of the even beat notes is moved to the third beat of the triplets.

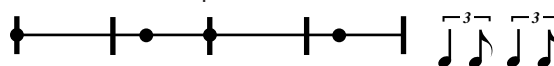

TIP

Save the edited song data to memory. (See page 45.)

Specifying whether playback starts immediately along with the first voicing [QuickPlay]

This parameter enables you to specify whether a song that starts from the middle of a bar, or a song with a silence prior to the first note, should be played from the first note or from the top of the bar (rest or blank).

See the procedure on page 63.

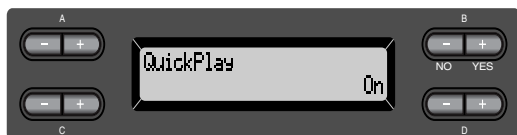

Setting range:

- [On] Playing from the first note
- [Off] Playing from the top of the bar (including a rest or blank)

Auditioning the channels [ChannelListen]

You can select a single channel to listen to its contents. Playback starts from the first note. See the procedure on page 63.

Playback continues as long as you press and hold down this button.



Use these buttons to select the desired channel for playback.

Setting range:

Ch1 - Ch16

TIP

Usually, channels that do not contain any data are not displayed. However, for some songs, all channels (including the channels that contain no data) may be displayed.

Deleting data from each channel [ChannelClear]

You can delete data from each of 16 channels. See the procedure on page 63.

Press this button to delete data.



Use these buttons to select the desired channel for deletion.

Setting range:

Ch1 - Ch16, ALL (all channels)

TIP

- Channels that do not contain any data are not displayed. However, for some songs, all channels (including the channels that contain no data) may be displayed.
- Save the edited song data to memory. (See page 45.)

Specifying the range and playing back repeatedly [From-ToRepeat]

You can specify a range (in steps of beats) in a song to play back repeatedly.

- Playback repeats after it reaches just prior to the beat specified as the end point.
 - If you start playing back a song with “Repeat On” selected, the count down starts, followed by the repeated playback of the specified part until you press the [TOP] button.
 - If you select “Repeat Off,” normal playback starts.
- See the procedure on page 63.

Use these buttons to select “Repeat On.”



Use these buttons to specify the start point of the repeated range.

Use these buttons to specify the end point of the repeated range.

TIP

Use the following buttons to specify the range to be repeated during song playback.
 C [-]/[+] specifies the start point of the repeat.
 D [-]/[+]specifies the end point of the repeat.

NOTE

When you select another song, the specified range is automatically cancelled and the Repeat function is turned off.

Playing back the phrase specified by the phrase number [PhraseMark]

If you select a song that contains phrase mark data, you can specify phrase numbers in the score to play back from the mark point, or to play back the phrase repeatedly.

- If you start playing back a song with “Repeat On” selected, the count down starts, followed by the repeated playback of the specified phrase until you press the [TOP] button.
- If you select “Repeat Off,” normal playback starts from the specified phrase.

See the procedure on page 63.

Use these buttons to select “Repeat On.”



Use these buttons to specify the phrase number.

Setting range of the phrase number:

Off (not specified)

1 - the last phrase number of the song

If you select a song that dose not contain phrase mark data, you can select only “Off.”

Playing back a song repeatedly [SongRepeat]

You can repeatedly play back all songs or a single song selected from the 50 preset songs.

- When you start playback, the PF-500 plays the song you selected using the front panel, then starts repeat playback of the specified songs until you press the [TOP] button.

See the procedure on page 63.

Use these buttons to select “On.”



Use these buttons to specify the repeated songs.

Setting range:

[MemorySongs] All songs in the PF-500’s memory

[PresetSongs] All 50 preset songs

[ALL] All songs from “MemorySongs” and “PresetSongs”

[OneSong] One song selected from the front panel

Detailed settings for the metronome METRONOME [SETTING]

You can set the time signature, volume level, and voice of the PF-500 metronome.

Procedure

Press the [METRONOME SETTING] button to access the Metronome Setting menu.

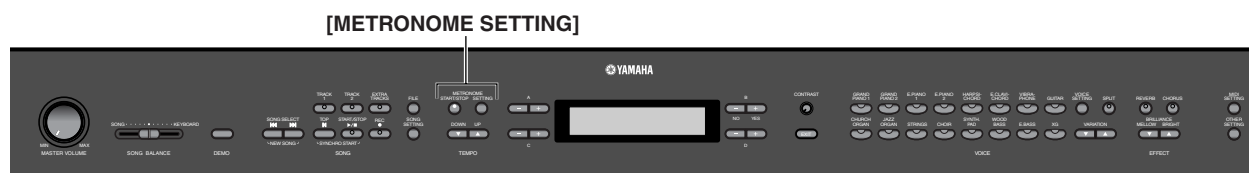

Setting the metronome time signature [TimeSignature]

See the procedure on page 63.

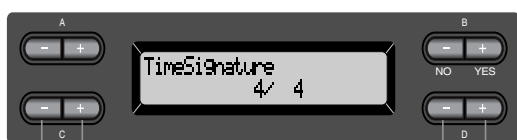

Use these buttons to set the numerator of the time signature.

Use these buttons to set the denominator of the time signature.

For example, to specify “3/4,” use the C [-]/[+] buttons to select “3” and the D [-]/[+] buttons to select “4.”

Setting range for the numerator:

1 - 16

Setting options for the denominator:

2, 4, and 8

Setting the metronome volume level [MetronomeVolume]

See the procedure on page 63.



Setting range:

0-127

Selecting the metronome voice [MetronomeSound]

See the procedure on page 63.



Setting range:

- [BellOff] Click (standard metronome sound)
- [EnglishVoice] Click and “1, 2, 3, 4” in English
- [GermanVoice] Click and “1, 2, 3, 4” in German
- [JapaneseVoice] Click and “1, 2, 3, 4” in Japanese
- [FrenchVoice] Click and “1, 2, 3, 4” in French
- [SpanishVoice] Click and “1, 2, 3, 4” in Spanish
- [BellOn] Click and bell

TIP

To mute the beat count, select “BellOff.”

Detailed settings for the voices [VOICE SETTING]

This menu enables you to make various detailed settings for the voices in Dual or Split mode and the effects. You can make these settings for each voice (or each combination of voices) individually. You can listen to the notes you play on the keyboard while changing the settings.

Procedure

1. Select a voice and press the [VOICE SETTING] button to access the “Voice Setting” menu.

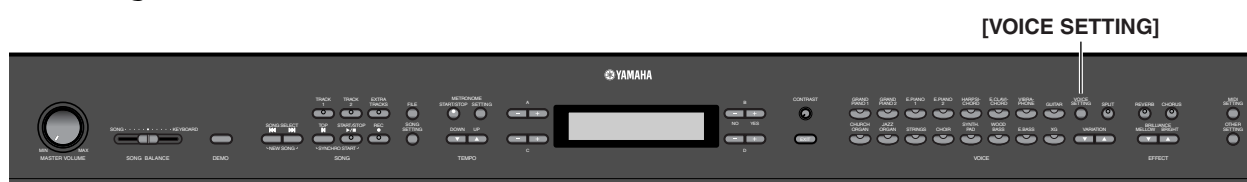

2. Press the A [-]/[+] buttons to select the part for which you wish to change the voice.

The range of the displayed part varies depending on the selected voice.

- [Main] MAIN voices (displayed with a single voice or in Split mode)
- [Main × Layer] MAIN Voice 1 and Voice 2 (displayed when the MAIN side is in Dual mode)
- [Left] LEFT voice (displayed in Split mode)
- [Left × Layer] LEFT Voice 1 and Voice 2 (displayed when the LEFT side is in Dual mode)

Detailed settings for the voices [VOICE SETTING]

TIP

In Dual mode, parameters with the “**” mark are set for Voice 1 and Voice 2 individually.

TIP

Parameter names enclosed in parentheses () are displayed in Dual mode.

Setting the octave [Octave]*

The pitch of a note can be shifted upward or downward in steps of an octave.

See the procedure on page 63.

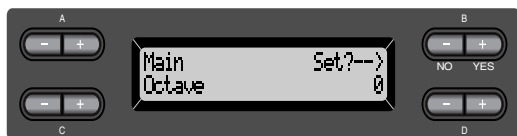

In Dual mode:



Voice for editing (Voice 1 or Voice 2)

Setting range:

-2 (two octaves lower) - 0 (no pitch shift) - +2 (two octaves higher)

Setting the volume level [Volume]*

You can set the volume level for each voice part. See the procedure on page 63.

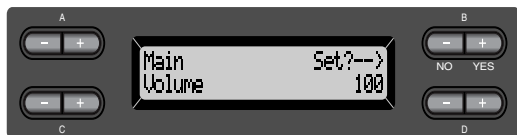

In Dual mode:



Voice for editing (Voice 1 and Voice 2)

Setting range:

0 - 127

Setting the position of right and left channels [Pan]*

You can specify the position in the stereo image from which you hear the sound.

See the procedure on page 63.



In Dual mode:



Voice for editing (Voice 1 or Voice 2)

Setting range:

L64 (hard left) - C (center) - R63 (hard right)

Make fine adjustments to the pitch (only in Dual mode) [Detune]

The pitch of the two sounds selected in Dual mode can be “skewed” slightly away from each other.

See the procedure on page 63.

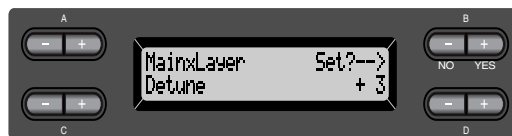

Setting range:

-20+20 (Positive (+) settings will raise the pitch of the first sound and lower the pitch of the second sound. Negative (-) settings will do the opposite.)

Selecting the reverb type [ReverbType]

TIP

You cannot set this parameter for the voice parts “Left” and “LeftXLayer.”

See the procedure on page 63.

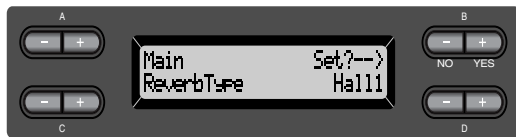

Setting range:

- Room Simulates reverberation in a room.
- Hall1 Simulates reverberation in a concert hall.
- Hall2 Reverberation is slightly longer than that of “Hall1.”
- Stage Reverberation suitable for a solo instrument sound.
- Plate Reverberation from the vibration of a metal plate.

Setting the reverb depth [ReverbSend]*

TIP

The reverb effect is not applied if the ReverbSend parameter is set to “0.”

See the procedure on page 63.

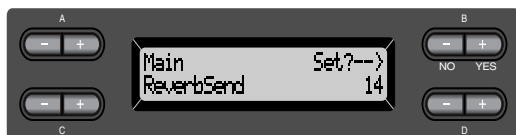

In Dual mode:



Voice for editing (Voice 1 or Voice 2)

Setting range:

0 - 127

Selecting the chorus type [Chorus Type]

TIP

You cannot set this parameter for the voice parts “Left” and “Left × Layer.”

See the procedure on page 63.



Setting range:

- Chorus Adds a rich, spacious sound.
- Celeste Adds swell and a spacious sound.
- Flanger Adds swell effects of an ascending or descending jet plane.

Setting the chorus depth [ChorusSend]*

See the procedure on page 63.



In Dual mode:

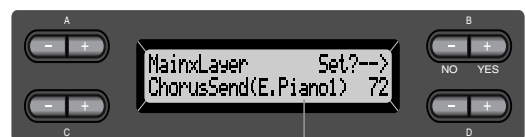

Voice for editing (Voice 1 or Voice 2)

Setting range:

0 - 127

Detailed settings for the voices [VOICE SETTING]

Setting the chorus on/off [ChorusOnOff]

You can set the [CHORUS] button on or off for each voice. When you select a voice, the chorus on/off setting for the voice automatically changes according to this parameter.

TIP

Even if this parameter is turned on, the chorus effect is disabled if the ChorusSend parameter is set to 0.

See the procedure on page 63.



Setting range:
On/Off

Selecting the DSP type* [DSP Type (DSP)]

You can select other effects (than reverb and chorus).

See the procedure on page 63.

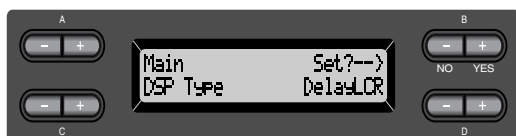

Setting range:

DelayLCR	Delay applied at left, center, and right positions.
DelayLR	Delay applied at left and right positions.
Echo	Echo-like delay
CrossDelay	Left and right delays are crossed.
Symphonic	Adds a rich and deep acoustic effect.
RotarySpeaker	Adds the vibrato effect of a rotary speaker.
Tremolo	The volume level changes in rapid cycles.
VibeRotor	The vibrato effect of a vibraphone.

AutoPan	The sound pans left to right and back and forth.
Phaser	The phase changes periodically, swelling the sound.
AutoWah	The center frequency of the wah filter changes periodically.
SoundBoardRev	Simulates the reverberation of a piano soundboard.
Off	No effect.

Setting the speed of the vibraphone vibrato effect* [VibeRotorSpeed]

TERMINOLOGY

Rotor= The rotating portion of an electrical device etc.

This will be displayed only if VibeRotor is selected for the DSP Type parameter explained above. This sets the speed of the vibrato effect that is applied when you have selected Vibraphone and are using the VibeRotor pedal. See the procedure on page 63.



Setting range:
1-10

Turning the vibraphone vibrato effect on/off* [VibeRotorOnOff (RotorOnOff)]

This will be displayed only if VibeRotor is selected for the DSP Type parameter explained above. It turns on/off the vibrato effect that is applied when you use the VibeRotor pedal. See the procedure on page 63.



Setting range:
On/Off

Setting the rotation speed of the rotary speaker* [RotarySpeed (Rot.Speed)]

This will be displayed only if RotarySpeaker is selected for the DSP Type parameter explained above. It sets the rotation speed of the rotary speaker effect. See the procedure on page 63.



Setting range:
Slow/Fast

Adjusting the depth of the DSP effect* [DSPDepth]

This sets the depth of the DSP effect (page 72). Some DSP Type settings do not allow you to set the DSPDepth. See the procedure on page 63.



Setting range:
1 (output only the original sound with almost no effect applied)–127 (output only the sound processed by the effect)

Adjusting the brightness of the sound* [Brightness]

See the procedure on page 63.

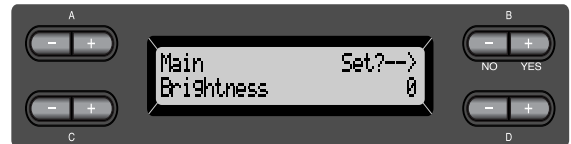

Setting range:
–64–+63

Adjusting the resonance effect* [HarmonicContent (Harmonic)]

TERMINOLOGY

Resonance= Sympathetic vibration

See the procedure on page 63.



Setting range:
–64–+63

Adjusting the low-range frequency of the equalizer* [EQ LowFreq. (EQ L.Freq)]

TERMINOLOGY

Equalizer:

An audio equalizer divides the frequency spectrum into multiple regions and enables the user to adjust the relative amplitude of each region.

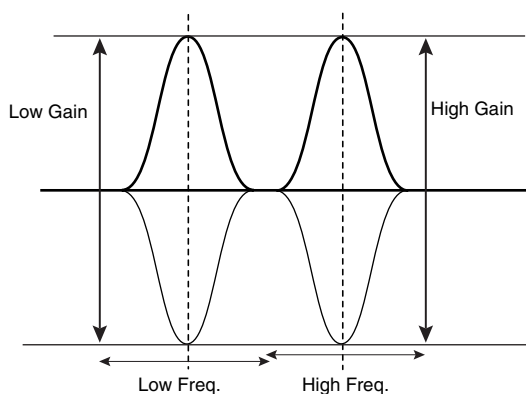

See the procedure on page 63.



Setting range:
32 Hz–2.0 kHz

Adjusting the low-range gain (amount of boost/cut) of the equalizer* [EQ LowGain]

See the procedure on page 63.

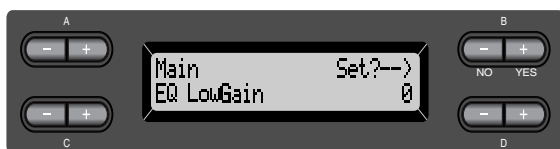

Setting range:
–12–+12 dB

Adjusting the high-range frequency of the equalizer* [EQ HighFreq. (EQ H.Freq)]

See the procedure on page 63.



Setting range:
500 Hz–16.0 kHz

Adjusting the high-range gain (amount of boost/cut) of the equalizer* [EQ HighGain]

See the procedure on page 63.



Setting range:
–12–+12 dB

Setting the touch sensitivity [TouchSense]*

This parameter enables/determines the manner and degree to which the volume level changes in response to your touch on the keyboard (how hard you play). Since the volume level of the harpsichords and pipe organs do not change regardless of how you play the keyboard, the normal setting for these voices is 127. (See the setting range below.) See the procedure on page 63.

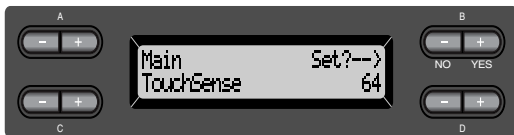

In Dual mode:

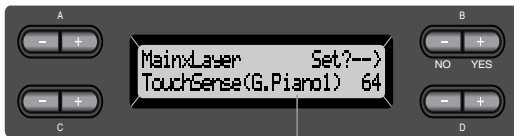

Voice for editing (Voice 1 or Voice 2)

Setting range:

0 (softest) - 64 (largest changes in the level) - 127 (loudest and fixed)

Setting the right pedal function [RPedal]

See the procedure on page 63.



Setting range:

- Sustain ON/OFF switch type damper
- SustainCont Damper that sustains the sound proportionately to how deeply you press the pedal
- Sostenuto Sostenuto (page 27)
- Soft Soft (page 27)
- Expression A function that lets you create changes in dynamics (volume) as you play
- PitchBend Up A function that smoothly raises the pitch
- PitchBend Down A function that smoothly lowers the pitch
- RotarySpeed Change the rotational speed of the JazzOrgan rotary speaker (switch between fast/slow each time you press the pedal)
- Viberotor Switch the vibraphone vibrato on/off (switch on/off each time you press the pedal)
- Off No function

Normal setting:

SustainCont

Setting the center pedal function [MPedal]

See the procedure on page 63.

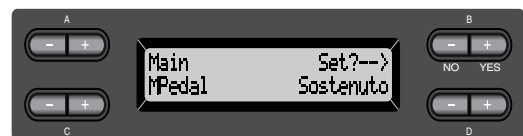

Setting range:

Same as "Specifying the function of the right pedal," above.

Normal Setting:

Sostenuto

Setting the left pedal function [LPedal]

See the procedure on page 63.

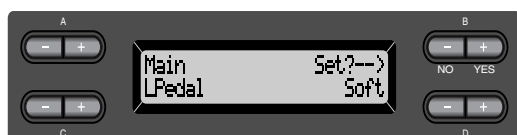

Setting range:

Same as "Right pedal function assignment" (page 75).

Normal Setting:

Soft (for all voices other than JazzOrgan and VibraPhone)

Rotary Speed (JazzOrgan), Vibraphone (VibeRotor)

Setting the auxiliary pedal function [AuxPedal]

You can assign a function to the pedal connected to the PF-500's AUX PEDAL jack.

See the procedure on page 63.



Setting range:

Same as "Right pedal function assignment" (page 75).

Normal setting:

Expression

TIP

YAMAHA FC7 foot controller

This foot controller is suitable for controlling Expression, SustainCont, or PitchBend Up/Down.

YAMAHA FC4 foot switch

YAMAHA FC5 foot switch

These foot switches are suitable for controlling Sustain, Sostenuto, Soft, RotarySpeed, or VibeRotor.

MIDI [MIDI SETTING]

You can make detailed MIDI settings, such as setting up MIDI transmit/receive channels.

About MIDI

MIDI (Musical Instrument Digital Interface) is a standard format for data transmission/reception. It enables the transfer of performance data and commands between MIDI devices and personal computers. Using MIDI, you can control a connected MIDI device from the PF-500, or control the PF-500 from a connected MIDI device or computer.

MIDI connectors

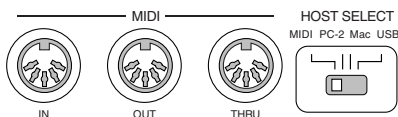

MIDI [IN]: Receives MIDI data.

MIDI [OUT]: Transmits MIDI data.

MIDI [THRU]: Transmits data received at the MIDI [IN] connector as it is.

TIP

Prepare dedicated MIDI cables.

[TO HOST] connector

Use this connector to connect the PF-500 to a computer.

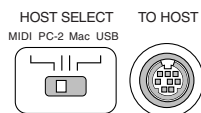

TIP

The type connecting cable varies depending on the computer. Refer to "Connecting a Personal Computer" on page 53 for more information.

[USB] connector

Use this connector to connect the PF-500 and computer.



TIP

MIDI performance data and commands are transferred in the form of numeric values.

Since MIDI data that can be transmitted or received varies depending on the type of MIDI device, check the "MIDI Implementation Chart" to find out what MIDI data and commands your devices can transmit or receive. The PF-500's MIDI Implementation Chart is listed on page 32 in the "Reference Booklet" for the PF-500.

When you are using the MIDI connectors, set the [HOST SELECT] switch to "MIDI." (See page 52.)

TIP

When you are using the [TO HOST] connector, set the [HOST SELECT] switch correctly, according to the type of computer you are using. (See page 52.)

NOTE

When you are using the [USB] connector, set the [HOST SELECT] switch to "USB."

TIP

You can also obtain detailed information about MIDI from various music magazines and books.

Procedure

Press the [MIDI SETTING] button to enter MIDI setting mode.

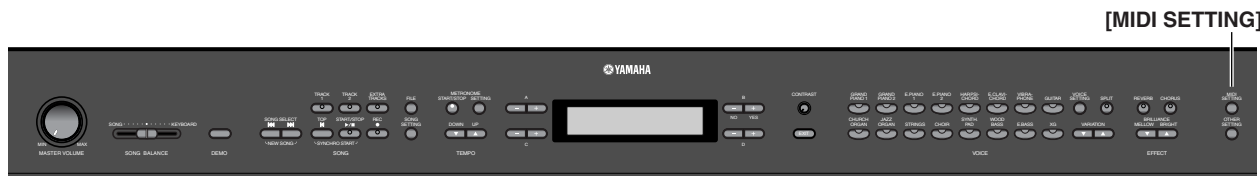

Setting the MIDI transmit channel [MidiOutChannel]

This parameter enables you to specify the channel on which the PF-500 transmits MIDI data. See the procedure on page 63.



Setting for:

Main, Left, Layer, Left Layer

Setting range:

Ch1 - Ch16, Off (Not transmitted.)

Normal setting:

- Main — Ch1
- Left — Ch2
- Layer — Ch3
- Left Layer — Ch4

Setting the MIDI receive channel [MidiInChannel]

You can specify whether each channel of data from MIDI [IN], [TO HOST], and [USB] will be received. See the procedure on page 63.

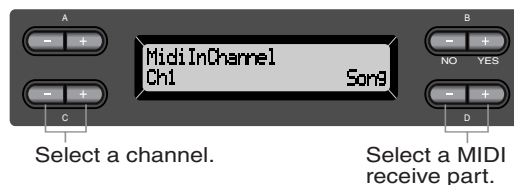

Setting for:

Ch1 - Ch32

Setting range:

Song, Main, Left, Layer, LeftLayer, Keyboard, Off

Normal setting:

- Ch1-16 — Song
- Ch17 — Keyboard
- Ch18 — Main
- Ch19 — Left
- Ch20 — Layer
- Ch21 — LeftLayer
- Others — Off

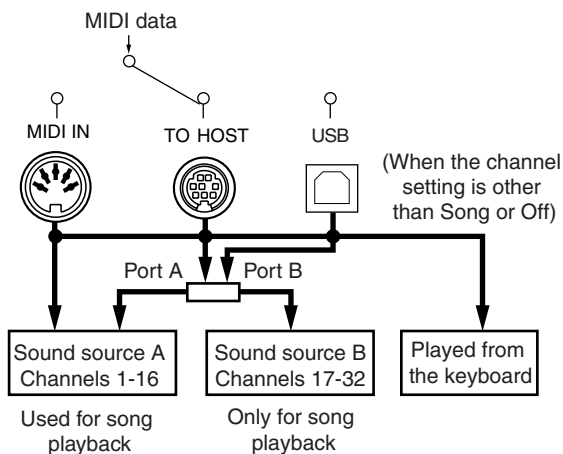

Setting Local control on/off [LocalControl]

“Local Control On” is a state in which the PF-500 produces the sound from its tone generator when you play the keyboard. In “Local Control Off” state, the keyboard and the tone generator are cut off from each other. This means that even if you play the keyboard, the PF-500 will not produce the sound. Instead, the keyboard data can be transmitted via MIDI to a connected MIDI device, which can produce the sound. The “Local Control Off” setting is useful when you wish to play an external sound source while playing the keys on the PF-500. See the procedure on page 63.

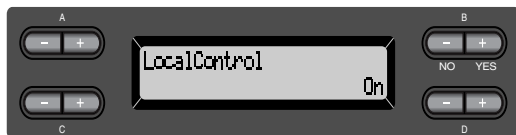

Setting range:

On/Off

Normal setting:

On

Selecting performance from the keyboard or song data for MIDI transmission [MidiOutSelect]

You can select whether your performance data or song playback data (including demo songs) is sent via MIDI.

See the procedure on page 63.



Setting range:

Keyboard performance data played on the keyboard

Song song playback data

Normal setting:

Keyboard

Selecting a type of data received via MIDI [ReceiveParameter]

This parameter enables you to specify which MIDI data the PF-500 can receive.

See the procedure on page 63.

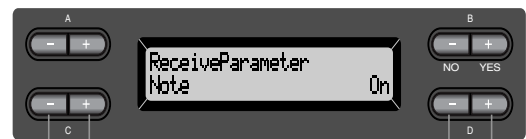

Select a type of data.

Select On or Off.

Type of data:

Note, Control, Program, Pitch Bend, SysEx (System Exclusive)

Setting range:

On/Off

Normal setting:

On for all types of data

Selecting a type of data transmitted via MIDI [TransmitParameter]

This parameter enables you to specify which MIDI data the PF-500 can transmit.

See the procedure on page 63.



Select a type of data.

Select On or Off.

Type of data:

Note, Control, Program, Pitch Bend, SystemReal-Time, SysEx (System Exclusive)

Setting range:

On/Off

Normal setting:

On for all types of data

Transmitting the initial settings on the panel [InitialSetup]

You can transmit the panel data, such as voice selection, to a connected sequencer. Before you record performance data to a connected MDF3 or sequencer, it is useful if you first send and record (at the beginning of the performance data) the panel setup data for your performance during playback.

See the procedure on page 63.



Executing voice data bulk dump [VoiceBulkDump]

You can transmit the voice data specified in the “Voice Setting” menu (page 69) as MIDI bulk data. You can interrupt voice data bulk dump transmission by pressing the B [- (NO)] button.

See the procedure on page 63.



Other settings

You can make detailed settings for touch, tuning, scale, etc.

Procedure

Press the [OTHER SETTING] button to enter Other Setting mode.

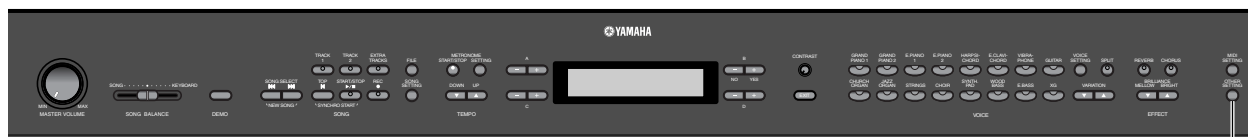

[OTHER SETTING]

Selecting a touch response [TouchResponse]

You can specify a touch response (how the sound responds to the way you play the keys). See the procedure on page 63.



Setting range:

- Light** With a soft touch, the PF-500 produces a loud sound. The volume level of tones tends to be consistent.
- Medium** Standard touch response.
- Heavy** You must hit the key very hard to generate a loud volume. This allows for versatile expression, from pianissimo to fortissimo tones.
- Fixed** No touch response. The volume level will be the same regardless of how hard you play the keys. Use the B [-]/[+] buttons to set the volume level.

Setting range of the "Fixed" volume level:

1 - 127

Fine tuning the pitch [Tune]

You can fine tune the pitch of the entire instrument. This function is useful when you play the PF-500 along with other instruments or CD music. See the procedure on page 63.



Setting range:

A3=427.0Hz - 453.0Hz (0.1Hz steps)

Selecting a tuning curve for a piano voice [PianoTuningCurve]

You can select a tuning curve from "GrandPiano1" and "GrandPiano2." Select "Flat" if you feel the tuning curve of the piano voice does not quite match that of other instruments voices. See the procedure on page 63.

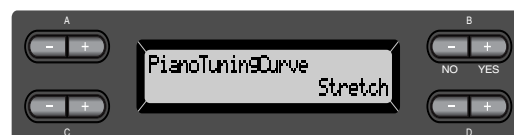

Setting range:

- Stretch** Tuning curve particularly for pianos
- Flat** Tuning curve in which the frequency is octave doubled over the entire keyboard range

Selecting a scale [Scale]

You can select various scales.

Equal Temperament is the most common contemporary piano tuning scale. However, history has known numerous other scales, many of which serve as the basis for certain genres of music. You can experience the tunings of these genres. See the procedure on page 63.

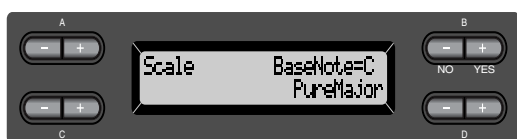

Setting range:

Equal

One octave is divided into twelve equal intervals. Currently most popular piano tuning scale.

PureMajor/PureMinor

Based on natural overtones, three major chords using these scales produce a beautiful, pure sound. They are sometimes used for chorus parts.

Pythagorean

This scale, designed by Pythagoras, a Greek philosopher, is based on the interval of a perfect 5th. The 3rd produces swells, but the 4th and 5th are beautiful and suitable for some leads.

MeanTone

This scale is an improvement of the Pythagorean in that the swell of the 3rd has been eliminated. It spread during the late 16th century through the late 18th century. Handel used this scale.

WerckMeister/KirnBerger

These scales combine Mean Tone and Pythagorean in different ways. With these scales, modulation changes the impression and feel of the songs. They were often used in the era of Bach and Beethoven. They are also often used now to reproduce the music of that era on harpsichords.

Normal setting:

Equal

If you select a scale other than Equal, you need to specify the root note using the B [-]/[+] buttons.



Setting range:

C, C[♯], D, E[♭], E, F, F[♯], G, A[♭], A, B[♭], B

Specifying the Split Point [SplitPoint]

You can specify the split point (the boundary between the right-hand and left-hand keyboard areas). See the procedure on page 63.



Setting range:

A-1-C7

NOTE

You can also use [SPLIT] to set the split point. (page 33)

Changing the key [Transpose]

TIP

TRANSCOPE= To change the key (Changing the key: To raise or lower the overall pitch of the entire song.)

The PF-500's Transpose function makes it possible to shift the pitch of the entire keyboard up or down in semi-tone intervals to facilitate playing in difficult key signatures, and to let you easily match the pitch of the keyboard to the range of a singer or other instruments. For example, if you set the transposition amount to "5," playing key C produces pitch F. In this way, you can play the song as if it were in C major, and the PF-500 will transpose it to the key of F.



Setting for:

Master The sound of the entire instrument (the manually-played sound and the song playback)
 Keyboard The manually-played sound
 Song The song playback

Setting range:

-12 (-1 octave)-0 (normal pitch)-+12 (+1 octave)

Adjusting the depth of the Soft pedal [SoftPedalDepth]

See the procedure on page 63.

**Setting range:**

1-10

Depth of string resonance [StringResonanceDepth]

This parameter is effective on the voices, such as "Grand Piano 1."

See the procedure on page 63.

**Setting range:**

Off, 1 - 10

Depth of sustain sampling for the damper pedal [SustainSamplingDepth]

This parameter is effective only on the voice group "GRANDPIANO1."

See the procedure on page 63.

**Setting range:**

Off, 1 - 10

Specify the volume of the key-off sound [KeyOffSamplingDepth]

You can adjust the volume of the key-off sound (the subtle sound that occurs when you release a key). This is effective on the voice groups "Grand Piano1," "Harpichord," and "E.Clavichord" and on the voice "E.Piano2."

See the procedure on page 63.

**Setting range:**

Off, 1 - 10

Selecting a pedal function for vibraphone [VibraphonePedalMode]

This parameter enables you to select whether the sound is sustained while you press the keys on the keyboard ("PianoLike") or the sound is sustained only while you press and hold down the sustain pedal, like playing a real vibraphone ("Normal"). See the procedure on page 63.

**Setting range:**

PianoLike, Normal

Normal setting:

PianoLike

Assign the SONG [START/STOP] function to the pedal [PedalStart/Stop]

TIP

If you assign the SONG START/STOP function to a pedal and turn the function On, the pedal function assigned to the pedal in the Voice Setting menu (pages 75 and 76) is disabled.

See the procedure on page 63.

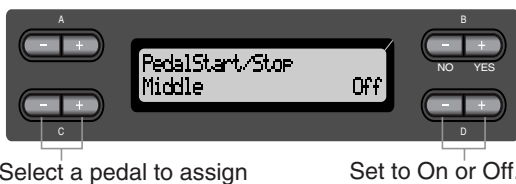

Select a pedal to assign the function.

Set to On or Off.

Setting for:
Left, Middle, AUX

Setting range:
On/Off

Normal setting:
Off for all pedals

Selecting a type of auxiliary pedal [AuxPedalType]

A pedal connected to the [AUX PEDAL] connector may switch on and off differently. For example, some pedals turn on the effects and others turn them off when you press them.

Use this parameter to reverse this mechanism. See the procedure on page 63.



Setting range:
Make, Break

Setting the point at which the damper pedal starts to affect the sound [HalfPedalPoint]

Here you can specify the point to which you must depress the pedal (right, center, left, AUX) before the assigned effect begins to be applied. (This setting applies to effects that can be assigned to each pedal, such as damper or sostenuto (page 75). Expression is not affected by this setting.)

If the effect is an on/off type effect, this setting specifies the point at which the effect will be switched on/off.



Setting range:
-2 (effective with the shallowest press) - 0 - +2 (effective with the deepest press)

Pitch bend range [PitchBendRange]

This specifies the amount of change that can be produced by the pitch bend function which smoothly varies the pitch.

- This setting applies only to the manually-played sound.
 - This setting can be made in semitone steps.
 - You can set the pedal function (page 75) to specify whether the pitch will be raised or lowered.
- See the procedure on page 63.



Setting range:
0-+12 (Pressing the pedal will raise/lower the pitch by 12 semitones [1 octave])

Normal setting:
-2

Switch the speaker on/off [Speaker]

This setting lets you switch the speaker on/off. See the procedure on page 63.

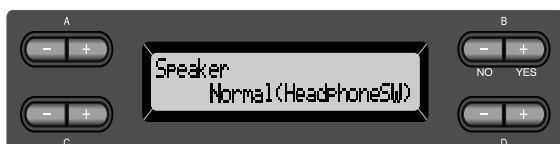

Normal (HeadphoneSW)

The speaker will sound only if headphones are not connected.

On The speaker will always sound.

Off The speaker will not sound.

Selecting items saved at shutdown [MemoryBackUp]

You can back up some settings, such as voice selection and metronome setting, so that they will not be lost after you turn off the power to the PF-500.

- Memory songs (saved in the PF-500's memory), the backup on/off setting (this parameter setting), and the "CharacterCode" parameter setting (page 47) are always backed up.

See the procedure on page 63.



Select the desired item.

Select on or off.

Setting for:

Transpose, Brilliance, ReverbOnOff, SplitPoint, Main/LeftVoice, MetronomeSetting, SongSetting, MidiSetting, and OtherSetting (except for Transpose and SplitPoint setting).

Setting range:

On/Off

Normal setting:

The Transpose, Main/LeftVoice, MetronomeSetting, and OtherSetting (except for Transpose and SplitPoint setting) parameters are set to Off. Other parameters are set to On.

Restoring the normal (default) settings [FactorySet]

You can reset the PF-500 to its normal (factory default) settings.

- The CharacterCode parameter setting in the File menu does not change.
- The MemoryBackUp parameter setting (On/Off) (left column) is reset to the normal setting.
- You can specify whether the memory songs are erased or kept.

See the procedure on page 63.

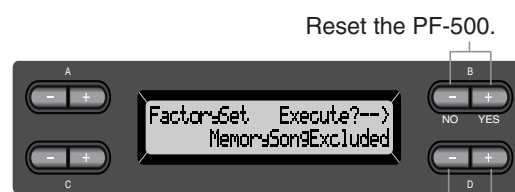

Reset the PF-500.

Select a value for memory songs.

Selecting for "MemorySong":

MemorySongExcluded	Memory songs are kept.
MemorySongIncluded	Memory songs are erased.

Other method for restoring the normal settings

Press and hold down the white key on the right end (C7) and press the [POWER] switch to turn on the power to the PF-500. In this case, the Memory songs saved in the storage memory are not erased. If you wish to erase Memory songs at this time, press and hold down the right-most white key (C7) and black key (B^b6) and press the [POWER] switch to turn on the power to the PF-500.

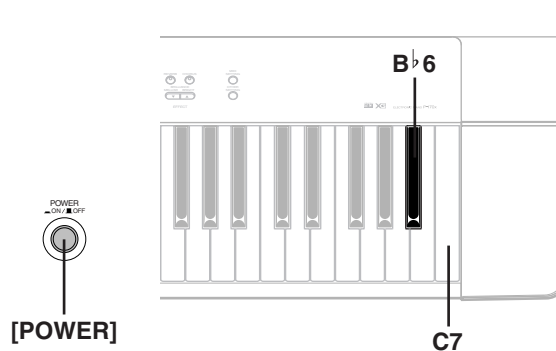







Message List

The messages are listed in alphabetical order.

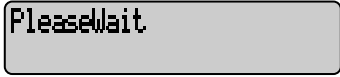





Message	Meaning
BulkDataReceiving Completed	This will be displayed following the “BulkDataReceiving Voice” message. This indicates that the PF-500 finished receiving the bulk data. Once you have verified this message, you may proceed to the next step.
BulkDataReceiving Error	Receiving bulk data has failed. Check the parameter settings and try again.
BulkDataReceiving Voice	The PF-500 is receiving the voice setting bulk data while this message is displayed. Wait until the message disappears, then proceed to the next step.
Canceled	This message confirms that in the “VoiceBulkDump” operation (page 80), you pressed B [-(NO)] to cancel while data was being transmitted.
Completed	This message is displayed following the message “Executing.” The PF-500’s internal processing is complete. You may proceed to the next step.
DuplicateName	When you attempted to rename a song and save it in “RenameSong” (page 47), this message will appear if an identically-named song already exists in the strage memory. Three seconds after this message is displayed, you will return to the previous screen. Please specify a different name.
Execute?→	This message prompts you to execute a file-related operation. Press the B [+ (YES)] button to proceed, or press the [EXIT] button to cancel.
Executing	The PF-500 is processing the data internally. Wait until the message disappears, then proceed to the next step.
FactorySet Completed MemorySongExcluded	The normal (factory default) settings (except for the memory song setting) (“FactorySet” on page 85) have been restored. This message also appears if you press and hold down the C7 key and turn on the power to the PF-500 (page 85).
FactorySet Completed MemorySongIncluded	The normal (factory default) settings (including the memory song setting) (“FactorySet” on page 85) have been restored. This message also appears if you press and hold down the C7 and B ^b 6 keys and turn on the power to the PF-500 (page 85).
FlashMemoryLifeTime Exit→	The PF-500’s flash memory (storage memory) has expired. Consult your Yamaha dealer. If this message appears, the PF-500 will not back up the songs and settings in memory. Press the [EXIT] button to return to the previous screen.

Message	Meaning
HostError	<p>There is a problem with the TO HOST/USB connector</p> <p>When using the PF-500 connected to your personal computer ... The driver or MIDI application on your computer is not functioning correctly, perhaps because the computer is turned off, the cable is not connected correctly, or the HOST SELECT switch is not set correctly. In this case, turn off the power of the PF-500 and your computer, and check the cable connections and HOST SELECT switch setting. Then turn on the power in the order of your computer → PF-500, and check that the driver and MIDI application on your computer are functioning correctly.</p> <p>When using the PF-500 by itself ... This message may appear if a cable is left connected to the [TO HOST] or [USB] connector of the PF-500. In this case, turn off the power of the PF-500, disconnect the cable, and then turn on the power again. If the cable is left connected, the PF-500 may not function correctly.</p>
LastPowerOffIllegalMemorySongChecking	<p>You turned off the power to the PF-500 while it was writing a song to storage memory. This message appears next time you turn on the power. The PF-500 checks if the contents of storage memory can be recovered.</p>
LastPowerOffIllegalMemorySongErrorRecovered	<p>This message appears following the message “LastPowerOffIllegalMemorySongChecking,” indicating that the PF-500 recovered data in the storage memory as much as possible.</p>
LastPowerOffIllegalMemorySongErased	<p>This message appears following the message “LastPowerOffIllegalMemorySongChecking,” indicating that the PF-500 could not recover data in the storage memory and that all memory songs were deleted.</p>
MemoryError	<p>While a preset song was being read, the PF-500 detected defects in memory. Reset the PF-500 to its normal (factory default) settings with “MemorySongIncluded” (page 85) after you back up all song data.</p>
MemoryError	<p>This message indicates that there may be a problem with the memory. If the message appears repeatedly when you continue using the PF-500, back up the song data, then restore the default setting by using “FactorySet” with “MemorySongIncluded” selected (page 85).</p>
MemoryFull	<p>There is not enough memory space left and you cannot save any more songs. Save or delete some songs in the storage memory, then save new data to memory.</p>
NoSong	<p>This message will appear if there is no song for the “SaveToMemory” (page 45) operation to save. In this case, no song will be saved.</p>
NoSongToDelete	<p>You tried to delete a song that does not exist in the storage memory. You cannot delete the song.</p>

Message List

Message	Meaning
	This message prompts you to select whether you wish to overwrite the existing data with new data when you add recordings to a song. Press the B [+ (YES)] button to allow overwriting. Press the B [- (NO)] button to cancel.
	You tried to start playing a song or perform another operation right after you select the song. Wait until the message disappears.
	You tried to copy or delete data in internally-protected files (such as commercially available music data). You cannot write to, copy, or delete such files.
	After you load an internally-protected song such as commercially available music data into the PF-500's Current memory or storage memory, you tried to save the song to a personal computer. You cannot save such a song to a personal computer etc.
	This message prompts you to select whether you wish to save the edited settings. Press the B [+ (YES)] button to save the settings. Press the [EXIT] button to cancel.
	You tried to perform another operation before saving the recorded song to storage memory. If you continue the operation, the recorded song will be lost. To delete the new recording, press the B [- (NO)] button. To keep the recording, press the B [+ (YES)] button. The PF-500 displays the "SaveToMemory" (page 45) parameter screen. Save the recorded song, then proceed to another operation.
	<ol style="list-style-type: none">1. This message will appear if a problem is found with the song data when you select a song or while the song is playing. In this case, re-select the song, and try once again to play it back. If the message still appears, the song data may have been damaged.2. This message will appear if a different "CharacterCode" (page 47) is selected than when you assigned the song name. In this case, switch the "CharacterCode", re-select the song, and play back.

Message List

Message	Meaning
	<ol style="list-style-type: none">1. This message will be displayed if current memory fills up during recording. Recording will stop automatically at this point. The data that had been recorded up to that point will remain. This message will also be displayed when you attempt to enter Record mode for additional recording if that song already occupies all of current memory. In this case, additional recording will not be possible. If there is an already-recorded track that you do not need to keep, you can use “ChannelClear” (page 66) to delete the unneeded track, so that you will then be able to record the equivalent amount of additional material.2. This message will be displayed when you select a song if that song is larger than the capacity of the current memory (page 90). This song cannot be loaded into the PF-500, and cannot be played back. Please select a different song.
	This message will be displayed when you edit a song if that song is larger than the capacity of the current memory (page 90). This song cannot be edited on the PF-500.
	This message prompts you to start the operation. To start, press the B [+ (YES)] button. Press the [EXIT] button to cancel the operation.
	This message prompts you to confirm the execution. Press the B [+ (YES)] button to continue. Press the B [- (NO)] button to cancel.
	This message means that the PF-500 was unable to transmit voice bulk data. If this message appears, make sure that the power of your computer is not turned off, that the cable is connected correctly, that the HOST SELECT switch is set correctly, and that the driver on your computer is functioning correctly. Then try transmitting the data once again.
	You used a period or space at the beginning of a song name or you tried to change a song name that includes a character (or characters) not supported by the PF-500, and the PF-500 could not process the name. The PF-500 displays the previous screen in three seconds. Rename the song correctly.

Questions about Operations and Functions

■ The buttons do not respond.

While you are using a function, some buttons not used for the function are disabled. If the song is playing, stop the playback. Otherwise, press the [EXIT] button to return to the main screen. Then, perform the desired operation.

■ The sound sustains and does not decay when I press the sostenuto pedal.

With the voices in the CHURCH ORGAN, JAZZ ORGAN, STRINGS, or CHOIR group, and some voices of [XG] group the sound continues sustaining while you are holding down the sostenuto pedal.

■ Higher or lower notes does not sound correctly when the transpose or octave setting is made.

The setting range for the transposition and octave setting is C-2 - G8. (With the normal setting, the PF-500's 88 keys covers the range of A-1 - C7.) If the lowest key is set to a note lower than C-2, it will produce a sound one octave higher. If the highest key is set to a note higher than G8, it will produce a sound one octave lower.

■ How can I return to the recording or song select screen during song recording or playback?

Press one of the SONG SELECT [◀◀] and [▶▶] buttons once.

■ The tempo does not change even though I recorded with tempo changes.

Depending on the timing of tempo changes, the changed tempo may not be recorded. In this case, the recording will be played back at the original tempo.

Make tempo changes when the recording track is selected and a red track indicator is flashing. The same trick applies to editing the tempo after recording.

■ Performance in Dual or Split mode is not recorded.

Track data is lost unexpectedly.

For Dual or Split mode recording, the recording track for the second voice (that is, the voice for the left-hand part) is automatically assigned (page 30). Therefore, if the track already has data, the data will be overwritten during recording. Also, switching to Dual mode or Split mode in the middle of the song is not recorded. Therefore, the notes you played with the second voice (or the notes lower than the Split point) are not recorded.

■ What type of data is recorded?

Data recorded in the tracks:

- Note data (notes you play)
- Voice selection
- PF-500 pedals and external pedal on/off
- Reverb depth [ReverbSend]
- Chorus depth [ChorusSend]
- DSP effect depth [DSPDepth]
- Sound brightness [Brightness]
- Resonance effect setting [Harmonic Content]
- Equalizer's low-range frequency setting [EQ LowFreq.]
- Equalizer's low-range gain setting [EQ LowGain]
- Equalizer's high-range frequency setting [EQ HighFreq.]
- Equalizer's high-range gain setting [EQ HighGain]
- Octave setting of the voice [Octave]
- Volume setting of each voice [Volume]
- Left/right position of each sound [Pan]
- Fine pitch adjustment between two voices (Dual only) [Detune]
- Volume change in response to playing strength for each voice [TouchSense]

Data recorded globally in all tracks:

- Tempo
- Time signature
- Reverb type
- Chorus type
- DSP effect type

You can change all data except for note data after recording.

You can change the time signature at the beginning of the song, or at a position in the song to which you move, by using the B [-]/[+] buttons while the song is stopped.

■ **I cannot change the key signature in the song after recording.**

Press the [TOP] button to locate the top of the song, use the B [-]/[+] buttons to locate the measure in which you wish to change the key signature, then change it.

■ **How much data can I record?**

- Current memory (page 45): About 800KB
- Storage memory (page 45): About 750KB

■ **The on/off setting of the pedal connected to the AUX PEDAL jack is reversed.**

Some types of pedals may turn on and off in opposite fashion. Use the “AuxPedalType” parameter (page 76) in the “OTHER SETTING” menu to change the external pedal setting.

■ **The song title is not correct.**

The “CharacterCode” setting may be different than that used when you named the song. Also, if the song was recorded on another instrument, the title might be displayed incorrectly. Use the “CharacterCode” parameter (page 47) in the FILE menu to change the setting. However, if the song was recorded on another instrument, changing the “CharacterCode” parameter setting may not resolve the problem.

■ **What is the difference between “TouchSense” and “TouchResponse” MIDI data?**

“TouchSense” determines the manner and degree to which the volume level changes in response to your touch on the keyboard. The MIDI note-on velocity data is not changed. It changes the volume level at the same velocity data.

“TouchResponse” determines the touch sensitivity of an instrument. The MIDI note-on velocity data is changed when you play the keyboard with a consistent touch.

MEMO

Appendix

Troubleshooting

Problem	Cause	Solution
The power of the PF-500 does not turn on.	The power cable is not plugged in (check at the PF-500 and at the electrical outlet).	Insert the power cable plug firmly into the PF-500 and into the electrical outlet of the correct voltage. (page 15)
There is a clicking noise when you press [POWER] to turn the power on or off.	This is caused by the electrical power within the instrument.	This is not a malfunction.
Noise is heard from the PF-500.	A portable telephone is being used near the PF-500 (or the ring tone is sounding).	Turn off the power of the portable telephone located near the PF-500. Noise may be heard if a portable telephone is used near the PF-500 or if the ring tone occurs.
The overall volume is too low. Or, there is no sound at all.	The [MASTER VOLUME] is lowered.	Raise [MASTER VOLUME]. (page 16)
	Headphones are connected (only if the Speaker setting is "Normal HeadphoneSW"). (page 85)	Disconnect the headphone plug.
	Speaker setting is off.	Set [Speaker] to "Normal" or "ON". (page 85)
	Local Control is turned off.	Set Local control ON. (page 79)
"Expression" is assigned to one of the right, center, and left pedals.		Assign any function other than "Expression" to the pedal.
The keyboard volume is lower than the song playback volume.	The volume level for the keyboard performance is set too low.	Move [SONG BALANCE] toward the keyboard to increase the keyboard volume.
Sound is still heard from the speakers even though headphones are plugged in.	Speaker setting is On.	Set the speaker setting to "Normal (HeadphoneSW)". (page 85)
Damper pedal does not function, or notes are sustained even though the damper pedal is not pressed.	The plug of the pedal unit is not inserted into the [PEDAL] jack.	Insert the plug firmly into the [PEDAL] jack. (page 14)

Data Compatibility

This section covers basic information on data compatibility: whether or not other MIDI devices can playback the data recorded by PF-500, and whether or not the PF-500 can playback commercially available song data or song data created for other instruments or on a computer.

Depending on the MIDI device or data characteristics, you may be able to play back the data without any problem, or you may have to perform some special operations before the data can be played back. If you run into problems playing back data, please refer to the information below.

Basic Check Points

The data and the MIDI device must match in regards to the items below.

- Sequence format
- Voice allocation format

Sequence Format

The system which records song data is called “sequence format.”

- Playback is only possible when the sequence format of the disk matches that of the MIDI device.

[Common Sequence Formats]

■ SMF (Standard MIDI File)

This is the most common sequence format.

- Standard MIDI Files are generally available as one of two types: Format 0 or Format 1.
- Many MIDI devices are compatible with Format 0, and most commercially available software is recorded as Format 0.
- The PF-500 is compatible with both Format 0 and Format 1.
- Performance data recorded on the PF-500 is saved in the SMF format 0 in a floppy disk.

■ ESEQ

This sequence format is compatible with many of Yamaha’s MIDI devices, including the PF-500 series instruments. This is a common format used with various Yamaha software.

- The PF-500 is compatible with ESEQ.

Voice Allocation Format

With MIDI, voices are assigned to specific numbers, called “program numbers.” The numbering standard (order of voice allocation) is referred to as the “voice allocation format.”

- Voices may not play back as expected unless the voice allocation format of the song data matches that of the compatible MIDI device used for playback.

[Main Voice Allocation Formats]

■ GM System Level 1

This is one of the most common voice allocation formats.

- Many MIDI devices are compatible with GM System Level 1, as is most commercially available software.
- The PF-500 is compatible with GM System Level 1.

■ XG

XG is a major enhancement of the GM System Level 1 format, and was developed by Yamaha specifically to provide more voices and variations, as well as greater expressive control over voices and effects, and to ensure compatibility of data well into the future.

- The PF-500 is compatible with XG.
- Performance data recorded with preset voices on the PF-500 can be played on other XG-compatible instruments.

■ DOC (Disk Orchestra Collection)

This voice allocation format is compatible with many of Yamaha’s MIDI devices, including the PF-500 series instruments.

This is also common format used with various Yamaha software.

The PF-500 is compatible with DOC.

- Even if the devices and data used satisfy all the conditions above, the data may still not be completely compatible, depending on the specifications of the devices and particular data recording methods.

Preset Voice List

○: YES, ×: No

Voice group	Voice name	Stereo sampling	Touch Sense	Dynamic sampling	Key-off samples	String resonance	Voice description
GRAND PIANO1	GrandPiano1	○	○	○	○	○	This sound was sampled from a full concert grand piano. Three stages of dynamics were sampled, and no effort has been spared in making the sound virtually identical to that of an acoustic piano. Even the tonal changes produced by the damper pedal and the subtle sounds of releasing a key are reproduced. The sympathetic vibration (string resonance) that occurs between the strings of an acoustic piano has also been simulated. Suitable not only for classical compositions but also for piano pieces of any style.
	MellowPiano	○	○	○	○	○	A warm and mellow piano sound. Ideal for classical music.
	RockPiano	○	○	○	○	○	A bright-sounding piano. Ideal for rock styles.
	HonkyTonk Piano	○	○	○	○	×	A honky-tonk style piano. Enjoy a tonal character that is quite different than a grand piano.
GRAND PIANO2	GrandPiano2	○	○	×	×	×	A spacious and clear piano sound with a bright resonance. Ideal for popular music.
	BrightPiano	○	○	×	×	×	A spacious and bright piano sound. Ideal for popular and rock music.
E.PIANO1	E.Piano1	×	○	○	×	×	An electronic piano sound produced by an FM synthesizer. The tone will change as you vary your playing touch. Ideal for popular music.
	SynthPiano	×	○	×	×	×	This voice simulates the electric piano sound produced by synthesizers in popular music. It also goes well with the acoustic piano sound.
E.PIANO2	E.Piano2	×	○	○	○	×	The sound of an electric piano using hammer-struck metallic "tines." Soft tone when played lightly, and an aggressive tone when played hard.
	Vintage E.Piano	×	○	○	×	×	A different type of electric piano sound. Widely used in rock and popular music.
HARPSICHORD	Harpsichord 8'	○	×	×	○	×	The sound of the instrument frequently used in baroque music. Variations in playing touch will not affect the volume, and a characteristic sound will be heard when you release the key.
	Harpsichord 8'+4'	○	×	×	○	×	A harpsichord with an added upper octave. Produces a more brilliant sound.
E.CLAVICHORD	E.Clavichord	×	○	×	○	×	This is the voice of a keyboard that produces sound by striking the strings with magnetic pickups. This funky sound is popular in black contemporary music. Because of its unique structure, the instrument produces a peculiar sound when you release the keys.
	Wah Clavi.	×	○	×	○	×	A distinctive effect is preset.
VIBRA-PHONE	Vibraphone	○	○	○	×	×	Vibraphone played with relatively soft mallets. The tone becomes more metallic the harder you play.
	Marimba	○	○	×	×	×	A marimba sound, sampled in stereo for spaciousness and realism.
	Celesta	○	○	○	×	×	The sound of a celesta (a percussion instrument in which hammers strike metallic bars to produce sound). This instrument is well-known for its appearance in "Dance of the Sugar-plum Fairies" from Tchaikovsky's "Nutcracker Suite."

Preset Voice List

Voice group	Voice name	Stereo sampling	Touch Sense	Dynamic sampling	Key-off samples	String resonance	Voice description
GUITAR	NylonGuitar	×	○	×	×	×	A warm and natural nylon-string guitar sound. Enjoy the atmosphere it adds to a quiet song.
	SteelGuitar	×	○	×	×	×	A bright steel guitar sound. Ideal for popular music.
CHURCH ORGAN	PipeOrgan Principal	○	×	×	×	×	This voice features the combination of pipes (8'+4'+2') of a principal (brass instrument) organ. It is suitable for Baroque church music.
	PipeOrgan Tutti	○	×	×	×	×	This voice features a full coupler of a pipe organ, famous for the sound used in Toccatta and Fugue by Bach.
	PipeOrgan Flute1	○	×	×	×	×	A pipe organ sound that combines flute-type (woodwind type) stops of different pitches (8' + 4'). This is a gentle sound that is ideal for accompanying hymns.
	PipeOrgan Flute2	○	×	×	×	×	A pipe organ sound that combines flute-type (woodwind type) stops of different pitches (8' + 4' + 1-1/3'). This is brighter than PipeOrganFlute1, and is suitable for solos.
JAZZORGAN	JazzOrgan	×	×	×	×	×	The sound of a "tonewheel" type electric organ. Often heard in jazz and rock idioms.
	RotaryOrgan	×	×	×	×	×	A bright electric organ sound.
	MellowOrgan	×	×	×	×	×	A mellow electric organ sound. Ideal for calmer songs.
STRINGS	Strings	○	○	×	×	×	Stereo-sampled, large-scale strings ensemble with realistic reverb. Try combining this voice with piano in the Dual mode.
	SynthStrings	×	○	×	×	×	A bright and spacious strings sound. Suitable for sustained parts in the background of an ensemble.
	SlowStrings	○	○	×	×	×	The sound of a string ensemble, with a slow attack. Suitable for use in Dual mode with GRAND PIANO or E.PIANO.
CHOIR	Choir	×	○	×	×	×	A big, spacious choir voice. Perfect for creating rich harmonies in slow pieces.
	SlowChoir	×	○	×	×	×	The sound of a choir with a slow attack. Suitable for use in Dual mode with GRAND PIANO or E.PIANO.
	Scat	×	○	○	×	×	You can enjoy jazz "scatting" with this voice. Depending on how hard and what note range you play, different sounds will be produced.
SYNTH.PAD	SynthPad1	×	○	×	×	×	A warm, mellow, and spacious synth sound. Ideal for sustained parts in the background of an ensemble.
	SynthPad2	×	○	×	×	×	A clear and spacious synth sound. Ideal for sustained parts in the background of an ensemble.
WOOD BASS	WoodBass	×	○	×	×	×	The sound of a finger-plucked upright bass. Frequently used in jazz and Latin music.
	Bass&Cymbal	×	○	×	×	×	The sound of a cymbal has been layered onto the bass. Effective when used for jazz walking-bass lines.
E.BASS	ElectricBass	×	○	×	×	×	The sound of an electric bass. Frequently used in jazz, rock, and popular music.
	FretlessBass	×	○	×	×	×	The sound of a fretless bass. Suitable for styles such as jazz and fusion.

Voice Combination Examples (Dual and Split)

Dual

MAIN + MAIN	GrandPiano1 + E.Piano1 GrandPiano1 + E.Piano2	This combination is often used in popular music.
MAIN + MAIN	GrandPiano1 + SynthPiano	This produces a fantasy, spacious piano sound.
MAIN + MAIN	GrandPiano2 + GrandPiano2	This combination sounds as if you are playing two notes that are one octave apart. It is suitable for the accompaniment of Salsa music.
MAIN + MAIN	E.Piano1 + SlowChoir	This is suitable for romantic ballads.
MAIN + MAIN	E.Piano2 + E.Clavichord	This is suitable for funk, rhythm & blues, and soul music.
MAIN + MAIN	Harpsichord8' + Strings	This combination is very suitable for Baroque music.
MAIN + MAIN	Celesta + SynthStrings	This combination adds strings and bell sound. A delay effect is automatically applied.

Split

MAIN / LEFT	GrandPiano1 / WoodBass or Bass&Cymbal	This is recommended for light Jazz music. The damper pedal is effective on the voice assigned to the right-hand range.
MAIN / LEFT	Celesta / Choir	This is suitable for a peaceful, somewhat cute song.
MAIN / LEFT	Choir / GrandPiano1	Play these voices elegantly along with piano arpeggio. Playing the Choir voice in chords would be more effective.
MAIN / LEFT	Scat / WoodBass	This combination features a cool (stylish) jazz chorus. The Scat voice is touch sensitive, adding a variety of expressions.
MAIN / LEFT	E.Piano2 / Scat	Playing the Scat voice for a bass part may create an interesting sound.

Dual + Split

MAIN + MAIN / LEFT	GrandPiano1 + SynthString / GrandPiano1	This combination creates the thick sound of a layered piano and strings.
MAIN + MAIN / LEFT	GrandPiano2 + E.Piano1 / ElectricBass	This sound is suitable for fusion. Deeper reverb and chorus (page 71) will improve the groove. The damper pedal is effective on the voice assigned to the right-hand range.
MAIN + MAIN / LEFT + LEFT	Harpsichord8' + 4' + Strings / Harpsichord8' + Strings	This combination makes a very brilliant sound.

Assembling the Keyboard Stand

You can use the PF-500 without installing the stand. However, if you wish to attach the stand to the PF-500, follow the steps below.

⚠ CAUTION

- Be careful not to confuse parts. Make sure that you install all parts in the correct orientation. Assemble the stand in accordance with the steps below.
- At least two persons should assemble the stand together.
- Be sure to use the correct-size screws, as indicated below. Use of incorrect screws can cause damages to the stand.
- When you attach each part, be sure to tighten all screws.
- Reverse the assembly procedure to disassemble the stand.

Use the included wrench.

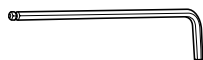

Keyboard

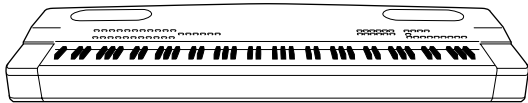

Remove the following parts from the package.

Plate

Stand

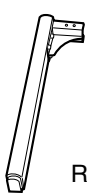
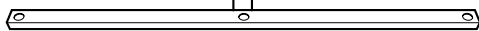

Front left leg



Rear left leg



Rear right leg



Front right leg

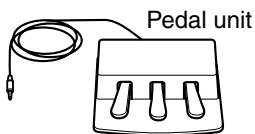

Pedal unit

AC power cord



Screws

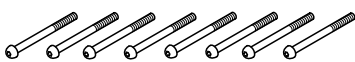

Long screws (6x65mm) x 8

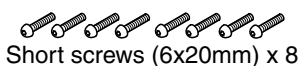

Short screws (6x20mm) x 8



Cap bolts x 4



Cord holders x 2



Wrench x 1

1. Attaching the front legs to the stand.

- 1 Place the stand on the floor so that the bottom side (with smaller holes) faces up.

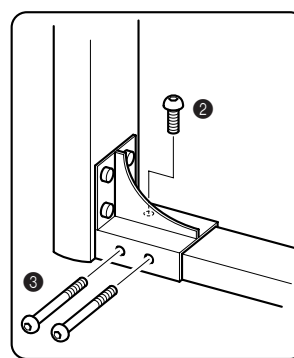
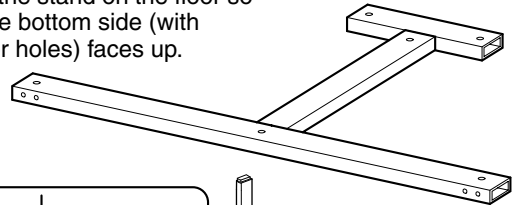

- 2 Use a short screw to attach the bracket of the front right leg to the bottom side of the stand.

- 3 Use two long screws to fix the bracket of the front right leg to the front side of the stand.

- 4 Attach the front left leg in the same way.

2. Attaching the rear legs to the stand.

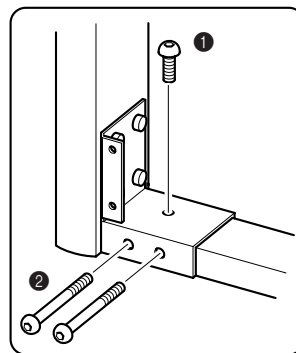

- 1 Use a short screw to attach the bracket of the rear left leg to the bottom side of the stand.

- 2 Use two long screws to fix the bracket of the rear left leg to the rear side of the stand.

- 3 Attach the rear right leg in the same way.

3. Attaching the plate.

Align the holes on the plate with the holes of the rear side of the bracket on the rear legs, then fix them using four short screws.

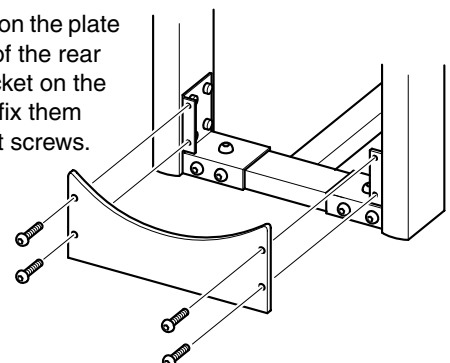

4. Raising the stand to the standing position.

Use the front legs as support to raise the stand.

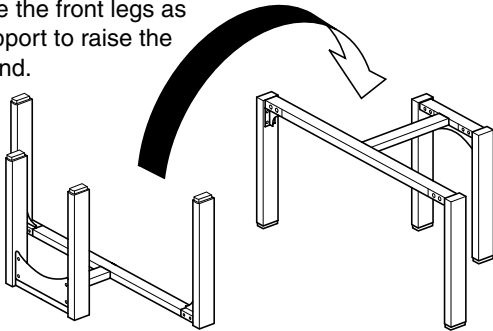

⚠ CAUTION

Be careful not to pinch your fingers.

5. Mounting the keyboard.

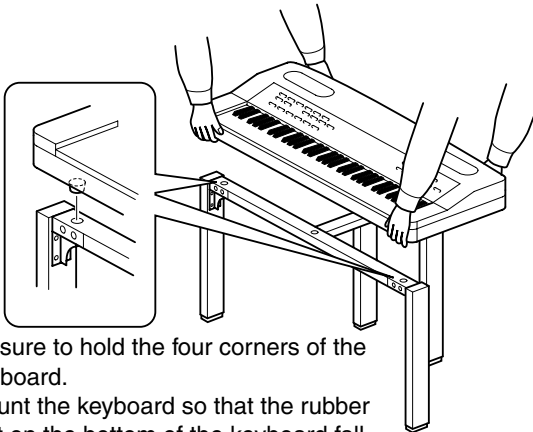

Be sure to hold the four corners of the keyboard. Mount the keyboard so that the rubber feet on the bottom of the keyboard fall into the holes on the stand.

⚠ CAUTION

Be careful not to pinch your fingers or drop the keyboard.

⚠ CAUTION

Do not hold any part of the keyboard other than four corners as shown in the illustration.

6. Fixing the keyboard.

Attach the cap bolts on the bottom of the stand and tighten them with your hand to fix the keyboard.

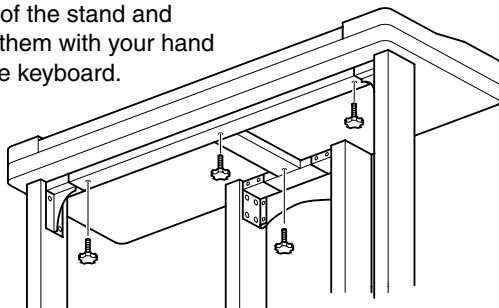

7. Connecting the pedal unit.

① Place the pedal unit in front of the rear legs.

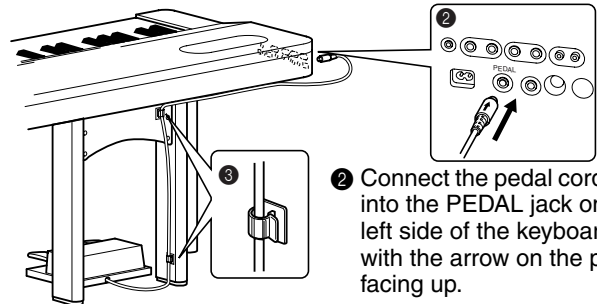

② Connect the pedal cord plug into the PEDAL jack on the left side of the keyboard, with the arrow on the plug facing up.

③ Attach the cord holders in the position shown in the illustration, and clip the pedal cord to the holders.

* You can also clip the power cord to the cord holders.

8. Set the voltage selector and connect the power cord to the AC INLET on the keyboard.

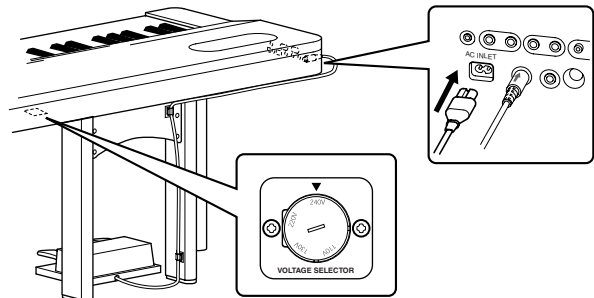

Voltage Selector

Before connecting the AC power cord, check the setting of the voltage selector (provided in some locations). To set the selector for 110V, 130V, 220V or 240V main voltages, use a "minus" screwdriver to rotate the selector dial so that the correct voltage for your region appears next to the pointer on the panel. The voltage selector is set at 240V when the unit is initially shipped.

After the proper voltage has been selected, connect the AC power cord to the AC INLET and an AC wall outlet. A plug adaptor may also be provided in some areas to match the pin configuration of the AC wall outlets in your area.

⚠ WARNING

An improper voltage setting can cause serious damage to the PF-500 or result in improper operation.

After completing the assembly, please check the following.

- **Are any parts left over?**
 - Review the assembly procedure and correct any errors.
- **Is the PF-500 clear of doors and other movable fixtures?**
 - Move the PF-500 to an appropriate location.
- **Does the PF-500 make a rattling noise when you shake it?**
 - Tighten all screws.
- **Are the pedal and power cords inserted securely into the sockets?**
 - Check the connections.
- **If the keyboard stand creaks or is otherwise unsteady when you play the keyboard, refer to the assembly diagrams and retighten all screws.**

Index

You can search the desired section using not only the terminology in this manual but also commonly-used words. The * mark indicates that the corresponding page includes the terminology explanation in the right column.

Numerics

- 50 Piano Preset Songs 22
- Practicing a one-hand part 24

A

- Adding variation to the sound
 - Effect function 28
- Assembly 100
- Assigning the START/STOP function to a pedal 84
- AUX IN jacks 51
- AUX OUT jacks 52
- AUX PEDAL jacks 52
- Auxiliary pedal function 76

B

- BackUp 85
- Bench 11
- BRILLIANCE 28

C

- Center pedal 27
- Center pedal function 75
- Character Code 47
- Characters 47
- CHORUS 29
- combining two voices
 - Dual mode 30
- Connection
 - Audio 52
 - computer 53
 - MIDI 56
 - Other Components 51
 - Serial 54
 - Speaker 51
 - USB 57
- Connectors
 - MIDI IN/OUT/THRU 52, 56
- CONTRAST* 16

D

- Damper (right) pedal 27
- Data Compatibility 95
- Data type 50

- Default (Normal) setting* 28
- Demonstration tunes 20
- Detailed Settings 60
 - Metronome 68
 - MIDI 77
 - Other settings 81
 - recording and playback 65
 - voices 69
- Display contrast 16
- DOWN (TEMPO)
 - 50 Piano Preset Songs 23
 - metronome 34

- Dual
 - Detailed settings 69
 - Recording 42
- Dual mode
 - combining two voices 30

E

- Effect function 28
- equalizer 74
- EXIT 19
- EXTRA TRACKS
 - the third or more tracks 40

F

- FactorySet 85
- Fast forward 23, 49
- FILE* 43

H

- Headphones 16
- HOST SELECT switch 52

J

- Jacks
 - AUX IN 51
 - AUX OUT 52
 - AUX PEDAL 52
 - PHONES 16
 - TO HOST 52, 54
 - USB 52

K

- Keyboard stand (assembly) 100

L

- LCD → Screen 19
 - Contrast 16
- Left pedal 27
- Left pedal function 76
- List
 - Demonstration tunes 20
 - Detailed Settings 60
 - Message 86
 - Preset Voice 97

M

- MASTER VOLUME* 16
- Memory 43
- Memory song 43
- MemoryBackUp 85
- Message List 86
- Metronome 34
 - Detailed settings 68
- METRONOME SETTING 68
- MIDI 77
 - Detailed settings 77
- MIDI cables 56
- MIDI connectors 53, 56
- MIDI driver 54
- MIDI SETTING 77
- Music stand 14

N

- New Song 35
- Normal setting* 28

O

- Other settings 81

P

- Pedal Function
 - Auxiliary 76
 - Center 75
 - Left 76
 - Right 75
- Pedal unit 14
- Pedals 27

Personal computer 53

PHONES jacks 16

Playback

50 Piano Preset Songs 22

Demo Songs 21

Recorded Songs 49

Playing back repeatedly (song) 67

Playing back repeatedly
(specifying the range) 66

playing two voices → Split mode 32

POWER 15

Practicing a one-hand part
(50 preset songs) 24

Preset song memory 43

Preset Voice List 97

R

Recording

Tape Recorder 52

Recording in Dual 42

Recording in Split 42

Recording Your Performance 35

Re-recording 37

REVERB 29

Rewind 23, 49

Right pedal 27

Right pedal function 75

S

Scale 82

Screen 19

Select

50 piano preset songs 22

Demo Songs 21

Recorded Songs 48

Selecting a touch response 81

SETTING

metronome 68

Volume 16

SMF (Standard MIDI File) 95

Soft (left) pedal 27

Song

Data Type 50

Delete 46

Detailed settings 65

Playing back repeatedly 67

Rename 47

Store 43

SONG [START/STOP]

50 Piano Preset Songs 22

Recorded Songs 49

Recording 36

SONG BALANCE 42

SONG SELECT

50 Piano Preset Songs 22

Recorded Songs 48

Recording 35

SONG SETTING 65

Sostenuto (center) pedal 27

Sound

brilliance 28

expression 28

reverberation 29

spread and spaciousness 29

Soundboard reverb 29

Split

Detailed settings 69

Recording 42

Split mode → playing two voices 32

Split point 33

Splitting the keyboard range and playing
two different voices 32

START/STOP

metronome 34

Storage memory 43

StringResonance 83

SustainSampling 83

Synchro Start

50 preset songs 24

Recorded Songs 49

T

TEMPO

50 Piano Preset Songs 23

metronome 34

Recorded Songs 49

the third or more tracks → EXTRA
TRACKS 40

TO HOST jack 52, 54

TOP

50 Piano Preset Songs 23

Recorded Songs 49

Recording 36

TouchResponse 81

Track playback on and off 50

TRACK1/TRACK2

50 Piano Preset Songs 24

Recording 35, 39

Troubleshooting 94

Tune 81

Type of characters 47

Type of data (recorded) 90

U

UP (TEMPO)

50 Piano Preset Songs 23

metronome 34

USB jack 52

V

Voice group buttons 26, 32

VOICE SETTING 69

Voices* 26

Detailed settings 69

Volume

Balance (SONG BLANCE) 42

Setting 16

X

XG 96

MEMO

IMPORTANT SAFETY INSTRUCTIONS

INFORMATION RELATING TO PERSONAL INJURY, ELECTRICAL SHOCK, AND FIRE HAZARD POSSIBILITIES HAS BEEN INCLUDED IN THIS LIST.

WARNING- When using any electrical or electronic product, basic precautions should always be followed. These precautions include, but are not limited to, the following:

- 1.** Read all Safety Instructions, Installation Instructions, Special Message Section items, and any Assembly Instructions found in this manual **BEFORE** making any connections, including connection to the main supply.
- 2.** Main Power Supply Verification: Yamaha products are manufactured specifically for the supply voltage in the area where they are to be sold. If you should move, or if any doubt exists about the supply voltage in your area, please contact your dealer for supply voltage verification and (if applicable) instructions. The required supply voltage is printed on the name plate. For name plate location, please refer to the graphic found in the Special Message Section of this manual.
- 3.** This product may be equipped with a polarized plug (one blade wider than the other). If you are unable to insert the plug into the outlet, turn the plug over and try again. If the problem persists, contact an electrician to have the obsolete outlet replaced. Do **NOT** defeat the safety purpose of the plug.
- 4.** Some electronic products utilize external power supplies or adapters. Do **NOT** connect this type of product to any power supply or adapter other than one described in the owners manual, on the name plate, or specifically recommended by Yamaha.
- 5.** **WARNING:** Do not place this product or any other objects on the power cord or place it in a position where anyone could walk on, trip over, or roll anything over power or connecting cords of any kind. The use of an extension cord is not recommended! If you must use an extension cord, the minimum wire size for a 25' cord (or less) is 18 AWG. **NOTE:** The smaller the AWG number, the larger the current handling capacity. For longer extension cords, consult a local electrician.
- 6.** Ventilation: Electronic products, unless specifically designed for enclosed installations, should be placed in locations that do not interfere with proper ventilation. If instructions for enclosed installations are not provided, it must be assumed that unobstructed ventilation is required.
- 7.** Temperature considerations: Electronic products should be installed in locations that do not significantly contribute to their operating temperature. Placement of this product close to heat sources such as; radiators, heat registers and other devices that produce heat should be avoided.
- 8.** This product was **NOT** designed for use in wet/damp locations and should not be used near water or exposed to rain. Examples of wet/damp locations are; near a swimming pool, spa, tub, sink, or wet basement.
- 9.** This product should be used only with the components supplied or; a cart, rack, or stand that is recommended by the manufacturer. If a cart, rack, or stand is used, please observe all safety markings and instructions that accompany the accessory product.
- 10.** The power supply cord (plug) should be disconnected from the outlet when electronic products are to be left unused for extended periods of time. Cords should also be disconnected when there is a high probability of lightning and/or electrical storm activity.
- 11.** Care should be taken that objects do not fall and liquids are not spilled into the enclosure through any openings that may exist.
- 12.** Electrical/electronic products should be serviced by a qualified service person when:
 - a. The power supply cord has been damaged; or
 - b. Objects have fallen, been inserted, or liquids have been spilled into the enclosure through openings; or
 - c. The product has been exposed to rain; or
 - d. The product does not operate, exhibits a marked change in performance; or
 - e. The product has been dropped, or the enclosure of the product has been damaged.
- 13.** Do not attempt to service this product beyond that described in the user-maintenance instructions. All other servicing should be referred to qualified service personnel.
- 14.** This product, either alone or in combination with an amplifier and headphones or speaker/s, may be capable of producing sound levels that could cause permanent hearing loss. **DO NOT** operate for a long period of time at a high volume level or at a level that is uncomfortable. If you experience any hearing loss or ringing in the ears, you should consult an audiologist. **IMPORTANT:** The louder the sound, the shorter the time period before damage occurs.
- 15.** Some Yamaha products may have benches and/or accessory mounting fixtures that are either supplied as a part of the product or as optional accessories. Some of these items are designed to be dealer assembled or installed. Please make sure that benches are stable and any optional fixtures (where applicable) are well secured **BEFORE** using. Benches supplied by Yamaha are designed for seating only. No other uses are recommended.

PLEASE KEEP THIS MANUAL

FCC INFORMATION (U.S.A.)

1. **IMPORTANT NOTICE: DO NOT MODIFY THIS UNIT!**

This product, when installed as indicated in the instructions contained in this manual, meets FCC requirements. Modifications not expressly approved by Yamaha may void your authority, granted by the FCC, to use the product.

2. **IMPORTANT:** When connecting this product to accessories and/or another product use only high quality shielded cables. Cable/s supplied with this product **MUST** be used. Follow all installation instructions. Failure to follow instructions could void your FCC authorization to use this product in the USA.
3. **NOTE:** This product has been tested and found to comply with the requirements listed in FCC Regulations, Part 15 for Class "B" digital devices. Compliance with these requirements provides a reasonable level of assurance that your use of this product in a residential environment will not result in harmful interference with other electronic devices. This equipment generates/uses radio frequencies and, if not installed and used according to the instructions found in the users manual, may cause interference harmful to the operation of

other electronic devices. Compliance with FCC regulations does not guarantee that interference will not occur in all installations. If this product is found to be the source of interference, which can be determined by turning the unit "OFF" and "ON", please try to eliminate the problem by using one of the following measures:

Relocate either this product or the device that is being affected by the interference.

Utilize power outlets that are on different branch (circuit breaker or fuse) circuits or install AC line filter/s.

In the case of radio or TV interference, relocate/reorient the antenna. If the antenna lead-in is 300 ohm ribbon lead, change the lead-in to co-axial type cable.

If these corrective measures do not produce satisfactory results, please contact the local retailer authorized to distribute this type of product. If you can not locate the appropriate retailer, please contact Yamaha Corporation of America, Electronic Service Division, 6600 Orangethorpe Ave, Buena Park, CA90620

The above statements apply **ONLY** to those products distributed by Yamaha Corporation of America or its subsidiaries.

* This applies only to products distributed by YAMAHA CORPORATION OF AMERICA.

(class B)

IMPORTANT NOTICE FOR THE UNITED KINGDOM

Connecting the Plug and Cord

IMPORTANT. The wires in this mains lead are coloured in accordance with the following code:

BLUE : NEUTRAL
BROWN : LIVE

As the colours of the wires in the mains lead of this apparatus may not correspond with the coloured markings identifying the terminals in your plug proceed as follows:

The wire which is coloured BLUE must be connected to the terminal which is marked with the letter N or coloured BLACK.

The wire which is coloured BROWN must be connected to the terminal which is marked with the letter L or coloured RED.

Making sure that neither core is connected to the earth terminal of the three pin plug.

(2 wires)

- This applies only to products distributed by Yamaha-Kemble Music (U.K.) Ltd.

CAUTION: TO PREVENT ELECTRIC SHOCK, MATCH WIDE BLADE OF PLUG TO WIDE SLOT, FULLY INSERT.

ATTENTION: POUR ÉVITER LES CHOCS ÉLECTRIQUES, INTRODUIRE LA LAME LA PLUS LARGE DE LA FICHE DANS LA BORNE CORRESPONDANTE DE LA PRISE ET POUSSER JUSQU'AU FOND.

(polarity)

- This applies only to products distributed by Yamaha Canada Music Ltd.
- Ceci ne s'applique qu'aux produits distribués par Yamaha Canada Musique Ltée.

For details of products, please contact your nearest Yamaha or the authorized distributor listed below.

Pour plus de détails sur les produits, veuillez-vous adresser à Yamaha ou au distributeur le plus proche de vous figurant dans la liste suivante.

Die Einzelheiten zu Produkten sind bei Ihrer unten aufgeführten Niederlassung und bei Yamaha Vertragshändlern in den jeweiligen Bestimmungsländern erhältlich.

Para detalles sobre productos, contacte su tienda Yamaha más cercana o el distribuidor autorizado que se lista debajo.

NORTH AMERICA

CANADA

Yamaha Canada Music Ltd.
135 Milner Avenue, Scarborough, Ontario,
M1S 3R1, Canada
Tel: 416-298-1311

U.S.A.

Yamaha Corporation of America
6600 Orangethorpe Ave., Buena Park, Calif. 90620,
U.S.A.
Tel: 714-522-9011

CENTRAL & SOUTH AMERICA

MEXICO

**Yamaha de Mexico S.A. De C.V.,
Departamento de ventas**
Javier Rojo Gomez No.1149, Col. Gpe Del
Moral, Deleg. Iztapalapa, 09300 Mexico, D.F.
Tel: 686-00-33

BRAZIL

Yamaha Musical do Brasil LTDA.
Av. Rebouças 2636, São Paulo, Brasil
Tel: 011-853-1377

ARGENTINA

Yamaha de Panamá S.A. Sucursal de Argentina
Viamonte 1145 Piso2-B 1053,
Buenos Aires, Argentina
Tel: 1-4371-7021

PANAMA AND OTHER LATIN AMERICAN COUNTRIES/ CARIBBEAN COUNTRIES

Yamaha de Panamá S.A.
Torre Banco General, Piso 7, Urbanización Marbella,
Calle 47 y Aquilino de la Guardia,
Ciudad de Panamá, Panamá
Tel: 507-269-5311

EUROPE

THE UNITED KINGDOM

Yamaha-Kemble Music (U.K.) Ltd.
Sherbourne Drive, Tilbrook, Milton Keynes,
MK7 8BL, England
Tel: 01908-366700

IRELAND

Danfay Ltd.
61D, Sallynoggin Road, Dun Laoghaire, Co. Dublin
Tel: 01-2859177

GERMANY/SWITZERLAND

Yamaha Europa GmbH.
Siemensstraße 22-34, 25462 Rellingen,
F.R. of Germany
Tel: 04101-3030

AUSTRIA

Yamaha Music Austria
Schleiergasse 20, A-1100 Wien Austria
Tel: 01-60203900

THE NETHERLANDS

Yamaha Music Nederland
Kanaalweg 18G, 3526KL, Utrecht, The Netherlands
Tel: 030-2828411

BELGIUM

Yamaha Music Belgium
Keiberg Imperiastraat 8, 1930 Zaventem, Belgium
Tel: 02-7258220

FRANCE

**Yamaha Musique France,
Division Professionnelle**
BP 70-77312 Marne-la-Vallée Cedex 2, France
Tel: 01-64-61-4000

ITALY

**Yamaha Musica Italia S.P.A.,
Combo Division**
Viale Italia 88, 20020 Lainate (Milano), Italy
Tel: 02-935-771

SPAIN/PORTUGAL

Yamaha-Hazen Electronica Musical, S.A.
Ctra. de la Coruna km. 17, 200, 28230
Las Rozas (Madrid) Spain
Tel: 91-201-0700

GREECE

Philippe Nakas S.A.
Navarinou Street 13, P.Code 10680, Athens, Greece
Tel: 01-364-7111

SWEDEN

Yamaha Scandinavia AB
J. A. Wettergrens Gata 1
Box 30053
S-400 43 Göteborg, Sweden
Tel: 031 89 34 00

DENMARK

YS Copenhagen Liaison Office
Generatorvej 8B
DK-2730 Herlev, Denmark
Tel: 44 92 49 00

FINLAND

F-Musiikki Oy
Kluuvikatu 6, P.O. Box 260,
SF-00101 Helsinki, Finland
Tel: 09 618511

NORWAY

Norsk filial av Yamaha Scandinavia AB
Grini Næringspark 1
N-1345 Østerås, Norway
Tel: 67 16 77 70

ICELAND

Skifan HF
Skeifan 17 P.O. Box 8120
IS-128 Reykjavik, Iceland
Tel: 525 5000

OTHER EUROPEAN COUNTRIES

Yamaha Europa GmbH.
Siemensstraße 22-34, 25462 Rellingen,
F.R. of Germany
Tel: 04101-3030

AFRICA

**Yamaha Corporation,
Asia-Pacific Music Marketing Group**
Nakazawa-cho 10-1, Hamamatsu, Japan 430-8650
Tel: 053-460-2312

MIDDLE EAST

TURKEY/CYPRUS

Yamaha Europa GmbH.
Siemensstraße 22-34, 25462 Rellingen,
F.R. of Germany
Tel: 04101-3030

OTHER COUNTRIES

Yamaha Music Gulf FZE
LB21-128 Jebel Ali Freezone
P.O.Box 17328, Dubai, U.A.E.
Tel: 971-4-881-5868

ASIA

HONG KONG

Tom Lee Music Co., Ltd.
11/F., Silvercord Tower 1, 30 Canton Road,
Tsimshatsui, Kowloon, Hong Kong
Tel: 2737-7688

INDONESIA

**PT. Yamaha Music Indonesia (Distributor)
PT. Nusantik**
Gedung Yamaha Music Center, Jalan Jend. Gatot
Subroto Kav. 4, Jakarta 12930, Indonesia
Tel: 21-520-2577

KOREA

Yamaha Music Korea Ltd.
Tong-Yang Securities Bldg. 16F 23-8 Yoido-dong,
Yongdungpo-ku, Seoul, Korea
Tel: 02-3770-0661

MALAYSIA

Yamaha Music Malaysia, Sdn., Bhd.
Lot 8, Jalan Perbandaran, 47301 Kelana Jaya,
Petaling Jaya, Selangor, Malaysia
Tel: 3-703-0900

PHILIPPINES

Yupangco Music Corporation
339 Gil J. Puyat Avenue, P.O. Box 885 MCPO,
Makati, Metro Manila, Philippines
Tel: 819-7551

SINGAPORE

Yamaha Music Asia Pte., Ltd.
11 Ubi Road #06-00, Meiban Industrial Building,
Singapore
Tel: 65-747-4374

TAIWAN

Yamaha KHS Music Co., Ltd.
10F, 150, Tun-Hwa Northroad,
Taipei, Taiwan, R.O.C.
Tel: 02-2713-8999

THAILAND

Siam Music Yamaha Co., Ltd.
121/60-61 RS Tower 17th Floor,
Ratchadaphisek RD., Dindaeng,
Bangkok 10320, Thailand
Tel: 02-641-2951

THE PEOPLE'S REPUBLIC OF CHINA AND OTHER ASIAN COUNTRIES

**Yamaha Corporation,
Asia-Pacific Music Marketing Group**
Nakazawa-cho 10-1, Hamamatsu, Japan 430-8650
Tel: 053-460-2317

OCEANIA

AUSTRALIA

Yamaha Music Australia Pty. Ltd.
Level 1, 99 Queensbridge Street, Southbank, Victoria
3006, Australia
Tel: 3-9693-5111

NEW ZEALAND

Music Houses of N.Z. Ltd.
146/148 Captain Springs Road, Te Papapa,
Auckland, New Zealand
Tel: 9-634-0099

COUNTRIES AND TRUST TERRITORIES IN PACIFIC OCEAN

**Yamaha Corporation,
Asia-Pacific Music Marketing Group**
Nakazawa-cho 10-1, Hamamatsu, Japan 430-8650
Tel: 053-460-2312

HEAD OFFICE Yamaha Corporation, Pro Audio & Digital Musical Instrument Division
Nakazawa-cho 10-1, Hamamatsu, Japan 430-8650
Tel: 053-460-2445



Yamaha Web Site (English only)
www.yamahasynt.com

Yamaha Manual Library
<http://www2.yamaha.co.jp/manual/english/>

This document is printed on recycled chlorine free (ECF) paper with soy ink.

M.D.G., Pro Audio & Digital Musical Instrument Division, Yamaha Corporation
©2002 Yamaha Corporation
V941880 205APAP1.3-01A0 Printed in Japan