

reface
CS

reface
DX

reface
CP

reface
YC

Contents

reface CS

MIDI Data Format.....	2
MIDI Data Table.....	4
MIDI Implementation Chart.....	5

reface DX

MIDI Data Format.....	6
MIDI Data Table.....	8
MIDI Implementation Chart...	10

reface CP

MIDI Data Format.....	11
MIDI Data Table.....	13
MIDI Implementation Chart...	14

reface YC

MIDI Data Format.....	15
MIDI Data Table.....	17
MIDI Implementation Chart...	19

MIDI Data Format

(1) Coverage

The specifications described herein specify transmission and reception of MIDI data of the reface CS.

(2) Compliance

The specifications described herein comply to the following standards:
 • MIDI 1.0

(3) TRANSMIT/RECEIVE DATA

(3-1) CHANNEL VOICE MESSAGES

(3-1-1) NOTE OFF

STATUS	1000nnnn (8nH)	n = 0 - 15 CHANNEL NUMBER
NOTE No.	0kkkkkkk	k = 0 (C-2) - 127 (G8)
VELOCITY	0vvvvvvv	v: ignored

Receive only

(3-1-2) NOTE ON/OFF

STATUS	1001nnnn (9nH)	n = 0 - 15 CHANNEL NUMBER
NOTE NUMBER	0kkkkkkk	k = 0 (C-2) - 127 (G8)
VELOCITY	NOTE ON 0vvvvvvv (v≠0) NOTE OFF 0vvvvvvv (v=0)	

(3-1-3) CONTROL CHANGE

STATUS	1011nnnn (BnH)	n = 0 - 15 CHANNEL NUMBER
CONTROL NUMBER	0ccccccc	
CONTROL VALUE	0vvvvvvv	

*TRANSMITTED CONTROL NUMBER
 c = 11 EXPRESSION ; v = 0 - 127
 c = 64 SUSTAIN SWITCH ; v = 0 - 127 *1

*1 When Sustain is set to "FC4/5," operating the foot switch transmits only values of 0 (off) or 127 (on).

*RECEIVED CONTROL NUMBER
 c = 1 MODULATION ; v = 0 - 127
 c = 7 VOLUME ; v = 0 - 127
 c = 11 EXPRESSION ; v = 0 - 127
 c = 64 SUSTAIN SWITCH ; v = 0 - 127

When MIDI Control Mode is turned on, Control Change numbers are assigned in order that voice parameter changes made using controllers on the front panel can be controlled via MIDI.
 See the following Control Change Table.

(3-1-4) PITCH BEND CHANGE

STATUS	1110nnnn (EnH)	n = 0 - 15 CHANNEL NUMBER
LSB	0vvvvvvv	PITCH BEND CHANGE LSB
MSB	0vvvvvvv	PITCH BEND CHANGE MSB

(3-2) CHANNEL MODE MESSAGES

STATUS	1011nnnn (BnH)	n = 0 - 15 CHANNEL NUMBER
CONTROL NUMBER	0ccccccc	c = CONTROL NUMBER
CONTROL VALUE	0vvvvvvv	v = DATA VALUE

(3-2-1) ALL SOUND OFF (CONTROL NUMBER = 78H , DATA VALUE = 0)

All the sounds currently played including the channel messages such as note-on and hold-on in a certain channel are muted when receiving this message.

(3-2-2) RESET ALL CONTROLLERS (CONTROL NUMBER = 79H , DATA VALUE = 0)

Resets the values set for the following controllers.
 PITCH BEND CHANGE 0 (center)
 MODULATION 0 (minimum)
 EXPRESSION 127 (maximum)
 SUSTAIN SWITCH 0 (off)

(3-2-3) ALL NOTE OFF (CONTROL NUMBER = 7BH , DATA VALUE = 0)

All the notes currently set to on in certain channel(s) are muted when receiving this message.
 However, if Sustain is on, notes will continue sounding until these are turned off.

(3-2-4) OMNI MODE OFF (CONTROL NUMBER = 7CH , DATA VALUE = 0)

Performs the same function as when receiving ALL NOTES OFF.
 Sets RECEIVE CHANNEL to channel 1.

(3-2-5) OMNI MODE ON (CONTROL NUMBER = 7DH , DATA VALUE = 0)

Performs the same function as when receiving ALL NOTES OFF.
 Sets RECEIVE CHANNEL to all.

(3-2-6) MONO (CONTROL NUMBER = 7EH , DATA VALUE = 0..16)

Performs the same function as when receiving ALL SOUNDS OFF.
 Sets PORTAMENTO to mono with portamento time 0.

(3-2-7) POLY (CONTROL NUMBER = 7FH , DATA VALUE = 0)

Performs the same function as when receiving ALL SOUNDS OFF.
 Sets PORTAMENTO to poly.

(3-3) SYSTEM REAL TIME MESSAGES

(3-3-1) ACTIVE SENSING

STATUS	11111110 (FBH)
--------	----------------

Transmitted at every 200 msec.
 Once this code is received, the instrument starts sensing.
 When no status nor data is received for over approximately 350 ms, MIDI receiving buffer will be cleared, and the sounds currently played is forcibly turned off.

(3-3-2) TIMING CLOCK

STATUS	11111000 (FBH)
--------	----------------

When received via MIDI IN or USB-MIDI IN, the instrument automatically switches to external synchronization. If no signal is received for 3 seconds, it switches back to the internal clock.

(3-3-3) START

STATUS	11111010 (FAH)
--------	----------------

(3-3-4) CONTINUE

STATUS	11111011 (FBH)
--------	----------------

(3-3-5) STOP

STATUS	11111100 (FCH)
--------	----------------

(3-4) SYSTEM EXCLUSIVE MESSAGE

(3-4-1) UNIVERSAL NON REALTIME MESSAGE

(3-4-1-1) IDENTITY REQUEST (Receive only)

F0H 7EH 0nH 06H 01H F7H
 ("n" = Device No. However, this instrument receives under "omni.")

(3-4-1-2) IDENTITY REPLY (Transmit only)

F0H 7EH 7FH 06H 02H 43H 00H 41H 51H 06H 00H 00H 00H 7FH F7H

(3-4-2) PARAMETER CHANGE

11110000	F0H	Exclusive status
01000011	43H	YAMAHA ID
0001nnnn	1nH	Device Number
01111111	7FH	Group Number High
00011100	1CH	Group Number Low
00000011	03H	Model ID
0aaaaaaaa	aaaaaaaa	Address High
0aaaaaaaa	aaaaaaaa	Address Mid
0aaaaaaaa	aaaaaaaa	Address Low
0ddddddd	ddddddd	Data
11110111	F7H	End of Exclusive

For parameters with data size of 2 or more, the appropriate number of data bytes will be transmitted.
 See the following MIDI Data Table for Address.

(3-4-3) BULK DUMP

11110000	F0H	Exclusive status
01000011	43H	YAMAHA ID
000nnnnn	0nH	Device Number
01111111	7FH	Group Number High
00011100	1CH	Group Number Low
0bbbbbbb	bbbbbbb	Byte Count
0bbbbbbb	bbbbbbb	Byte Count
00000011	03H	Model ID
0aaaaaaaa	aaaaaaaa	Address High
0aaaaaaaa	aaaaaaaa	Address Mid
0aaaaaaaa	aaaaaaaa	Address Low
0	0	Data
0ccccccc	ccccccc	Check-sum
11110111	F7H	End of Exclusive

See the following BULK DUMP Table for Address and Byte Count.
 Byte Count shows the size of data in blocks from Model ID onward (up to but not including the checksum).
 The Check sum is the value that results in a value of 0 for the lower 7 bits when the Model ID, Start Address, Data and Check sum itself are added.

(3-4-4) DUMP REQUEST

11110000	F0H	Exclusive status
01000011	43H	YAMAHA ID
0010nnnn	2nH	Device Number
01111111	7FH	Group Number High
00011100	1CH	Group Number Low
00000011	03H	Model ID
0aaaaaaaa	aaaaaaaa	Address High
0aaaaaaaa	aaaaaaaa	Address Mid
0aaaaaaaa	aaaaaaaa	Address Low
11110111	F7H	End of Exclusive

See the following DUMP REQUEST Table for Address and Byte Count.

(3-4-5) PARAMETER REQUEST

11110000	F0H	Exclusive status
01000011	43H	YAMAHA ID
0011nnnn	3nH	Device Number
01111111	7FH	Group Number High
00011100	1CH	Group Number Low
00000011	03H	Model ID
0aaaaaaaa	aaaaaaaa	Address High
0aaaaaaaa	aaaaaaaa	Address Mid
0aaaaaaaa	aaaaaaaa	Address Low
11110111	F7H	End of Exclusive

See the following MIDI Data Table for Address.

(4) SYSTEM OVERVIEW (Keyboard (KBD), Looper Play/Rec (LPR PLAY/REC) and Tone Generator (TG))

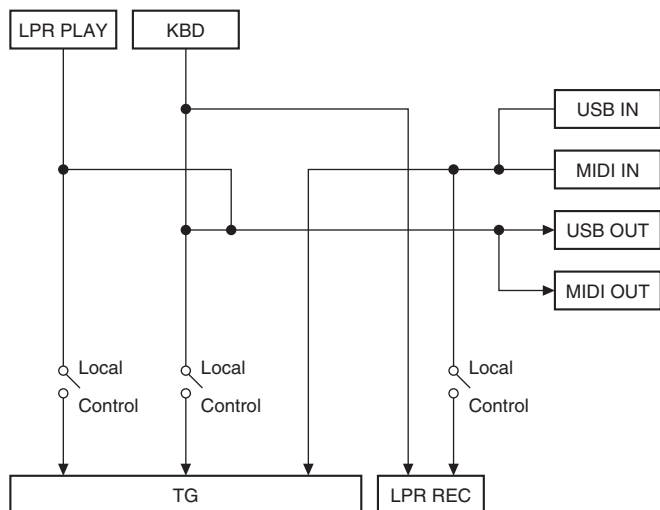

MIDI Data Table

Control Change

Transmitted and recognized Control Change Number and Value, when MIDI control is on.

Control Change Number			Control Value		Notes
Name	No.	Description	Transmitted	Recognized	
LFO ASSIGN	78	OFF	0	0 – 25	
		AMP	32	26 – 51	
		FILTER	64	52 – 76	
		PITCH	95	77 – 102	
		OSC (Oscillator)	127	103 – 127	
LFO DEPTH	77	—	0 – 127	0 – 127	
LFO SPEED	76	—	0 – 127	0 – 127	
PORTAMENTO	20	Poly	0	0	
		Mono with Portamento Time	1 – 127	1 – 127	
OSC TYPE	80	Multi-saw	0	0 – 25	
		Pulse	32	26 – 51	
		Oscillator Sync	64	52 – 76	
		Ring Modulation	95	77 – 102	
		Frequency Modulation	127	103 – 127	
OSC TEXTURE	81	—	0 – 127	0 – 127	
OSC MOD (modulation)	82	—	0 – 127	0 – 127	
FILTER CUTOFF	74	—	0 – 127	0 – 127	
FILTER RESONANCE	71	—	0 – 127	0 – 127	
EG FEG – AEG (balance)	83	—	0 – 127	0 – 127	
EG A (attack time)	73	—	0 – 127	0 – 127	
EG D (decay time)	75	—	0 – 127	0 – 127	
EG S (sustain level)	79	—	0 – 127	0 – 127	
EG R (release time)	72	—	0 – 127	0 – 127	
EFFECT TYPE	17	DIST	0	0 – 25	
		CHO/FLA	32	26 – 51	
		PHASER	64	52 – 76	
		DELAY	95	77 – 102	
		OFF (thru)	127	103 – 127	
EFFECT DEPTH	18	—	0 – 127	0 – 127	
EFFECT RATE	19	—	0 – 127	0 – 127	

Parameter Base Address

Parameter Block	Top Address (hex)			Description
	High	Mid	Low	
	SYSTEM	00	00	
TG	30	00	00	

Bulk Dump Block

"Top Address" indicates the top address of each block designated by bulk dump operation.

Byte Count shows the size of data in blocks from Model ID onward (up to but not including the checksum).

To carry out TG bulk dump request, designate its corresponding BulkHeader address.

Parameter Block	Description	Byte Count		Top Address (hex)		
		Dec	Hex	High	Mid	Low
SYSTEM	Common	36	24	00	00	00
TG	Bulk Header	4	04	0E	0F	00
	COMMON	TG Common	26	1A	30	00
	Bulk Footer	4	04	0F	0F	00

MIDI PARAMETER CHANGE TABLE (SYSTEM)

Address (hex)			Size	Data Range (hex)	Parameter Name	Description	Notes
High	Mid	Low					
00	00	00	1	00 – 0F, 7F	MIDI transmit channel	1 – 16, off	
		01	1	00 – 0F, 10	MIDI receive channel	1 – 16, All	
		02	4	00 – 00 00 – 07 00 – 0F 00 – 0F	Master Tune	-102.4 – +102.3 (cent) 1st bit 3-0 : bit 15-12 2nd bit 3-0 : bit 11-8 3rd bit 3-0 : bit 7-4 4th bit 3-0 : bit 3-0	
		06	1	00 – 01	Local Control	off, ON	
		07	1	34 – 4C	Master Transpose	-12 – +12 (semitones)	
		08	2	00 – 02 00 – 7F	Tempo MSB Tempo LSB	30 – 300 1st bit 6-0 : bit 13-7 2nd bit 6-0 : bit 6-0	
		0A	1		reserved		
		0B	1	00 – 01	Sustain Pedal Select (SUSTAIN)	FC3, FC4/5	
		0C	1	00 – 01	Auto Power-Off	off, ON	
		0D	1	00 – 01	Speaker Output	off, ON	
		0E	1	00 – 01	MIDI Control	off, ON	
		0F	1	28 – 58	Pitch Bend Range	-24 – +24 (semitones)	
		10	1		reserved		
		11	1		reserved		
		12	1		reserved		
		13	1		reserved		
		14	1	00 – 01	Foot Volume/ Sustain switch	Foot Volume, Sustain	
		15	1		reserved		
		16	1		reserved		
		17	1		reserved		
		18	1		reserved		
		19	1		reserved		
		1A	1		reserved		
		1B	1		reserved		
		1C	1		reserved		
		1D	1		reserved		
		1E	1		reserved		
		1F	1		reserved		

Total Size = 32

MIDI PARAMETER CHANGE TABLE (Tone Generator)

Address (hex)			Size	Data Range (hex)	Parameter Name	Description	Notes
High	Mid	Low					
30	00	00	1	00 – 7F	Volume	0 – 127	This parameter can be set only via MIDI.
		01	1		reserved		
		02	1	00 – 04	LFO Assign	OFF, AMP, FILTER, PITCH, OSC (Oscillator)	
		03	1	00 – 7F	LFO Depth	0 – 127	
		04	1	00 – 7F	LFO Speed	0 – 127	
		05	1	00 – 7F	Portamento	0: Poly, 1 – 127: Mono with Portamento Time	
		06	1	00 – 04	OSC Type	Multi-saw, Pulse, Oscillator Sync, Ring Modulation, Frequency Modulation	
		07	1	00 – 7F	OSC Texture	0 – 127	
		08	1	00 – 7F	OSC Mod (Modulation)	0 – 127	
		09	1	00 – 7F	Filter Cutoff Frequency	0 – 127	
		0A	1	00 – 7F	Filter Resonance	0 – 127	
		0B	1	00 – 7F	EG Balance	AEG max – FEG max	
		0C	1	00 – 7F	EG A (attack time)	0 – 127	
		0D	1	00 – 7F	EG D (decay time)	0 – 127	
		0E	1	00 – 7F	EG S (sustain level)	0 – 127	
		0F	1	00 – 7F	EG R (release time)	0 – 127	
		10	1	00 – 04	Effect Type	DIST, CHO/FLA, PHASER, DELAY, OFF (thru)	
		11	1	00 – 7F	Effect Depth	0 – 127	
		12	1	00 – 7F	Effect Rate (*Note)	0 – 127	DIST: tone CHO/FLA, PHASER: rate DELAY: delay time
		13	3		reserved		

Total Size = 22

MIDI Implementation Chart

YAMAHA [Mobile Mini Keyboard]
 Model reface CS MIDI Implementation Chart

Date :31-MAR-2016
 Version : 1.1

Function...	Transmitted	Recognized	Remarks
Basic Channel	Default 1 Changed 1 - 16	1 - 16 1 - 16	
Mode	Default 3 Messages x Altered *****	1 1 - 4 (m=1) *2 x	
Note Number : True voice	24 - 108 *****	0 - 127 0 - 127	Transpose
Velocity	Note ON o 9nH,v=1-127 Note OFF x 9nH,v=0	o v=1-127 x	
After Touch	Key's x Ch's x	x x	
Pitch Bend	o	o	
Control Change	1 x 7 x 11 o *3 64 o *4 17-20 o *1 71-83 o *1	o o o o o *1 o *1	Modulation Wheel Main Volume Expression Sustain Sw
Prog Change : True #	x *****	x x	
System Exclusive	o	o	
Common : Song Pos. : Song Sel. : Tune	x x x	x x x	
System : Clock Real Time : Commands	o o	o o	
Aux : All Sound Off : Reset All Cntrls : Local ON/OFF Mes- : All Notes OFF sages: Active Sense : Reset	x x x x o x	o (120,126,127) o (121) x o (123-125) o x	
Notes:*1 Transmitted and recognized if MIDI control mode is on. *2 "m" is always treated as "1" regardless of its actual value. *3 Transmitted if Foot Volume / Sustain switch is Foot Volume. *4 Transmitted if Foot Volume / Sustain switch is Sustain.			

Mode 1 : OMNI ON , POLY Mode 2 : OMNI ON ,MONO o : Yes
 Mode 3 : OMNI OFF, POLY Mode 4 : OMNI OFF,MONO x : No

MIDI Data Format

(1) Coverage

The specifications described herein specify transmission and reception of MIDI data of the reface DX.

(2) Compliance

The specifications described herein comply to the following standards:
 • MIDI 1.0

(3) TRANSMIT/RECEIVE DATA

(3-1) CHANNEL VOICE MESSAGES

(3-1-1) NOTE OFF

STATUS	1000nnnn (8nH)	n = 0 - 15 CHANNEL NUMBER
NOTE No.	0kkkkkkk	k = 0 (C-2) - 127 (G8)
VELOCITY	0vvvvvvv	v: ignored

Receive only

(3-1-2) NOTE ON/OFF

STATUS	1001nnnn (9nH)	n = 0 - 15 CHANNEL NUMBER
NOTE NUMBER	0kkkkkkk	k = 0 (C-2) - 127 (G8)
VELOCITY	NOTE ON 0vvvvvvv (v≠0)	
	NOTE OFF 0vvvvvvv (v=0)	

(3-1-3) CONTROL CHANGE

STATUS	1011nnnn (BnH)	n = 0 - 15 CHANNEL NUMBER
CONTROL NUMBER	0ccccccc	
CONTROL VALUE	0vvvvvvv	

*TRANSMITTED CONTROL NUMBER
 c = 64 SUSTAIN SWITCH ; v = 0 - 127 *1

*1 When Sustain is set to "FC4/5," operating the foot switch transmits only values of 0 (off) or 127 (on).

*RECEIVED CONTROL NUMBER
 c = 1 MODULATION ; v = 0 - 127
 c = 7 VOLUME ; v = 0 - 127
 c = 11 EXPRESSION ; v = 0 - 127
 c = 64 SUSTAIN SWITCH ; v = 0 - 127

When MIDI Control Mode is turned on, Control Change numbers are assigned in order that voice parameter changes made using controllers on the front panel can be controlled via MIDI.
 See the following Control Change Table.

(3-1-4) PROGRAM CHANGE

STATUS	1100nnnn (CnH)	n = 0 - 15 CHANNEL NUMBER
PROGRAM NUMBER	0ppppppp	p = 0 - 31

Bank1-1 ... 8	0 - 7
Bank2-1 ... 8	8 - 15
Bank3-1 ... 8	16 - 23
Bank4-1 ... 8	24 - 31

(3-1-5) PITCH BEND CHANGE

STATUS	1110nnnn (EnH)	n = 0 - 15 CHANNEL NUMBER
LSB	0vvvvvvv	PITCH BEND CHANGE LSB
MSB	0vvvvvvv	PITCH BEND CHANGE MSB

(3-2) CHANNEL MODE MESSAGES

STATUS	1011nnnn (BnH)	n = 0 - 15 CHANNEL NUMBER
CONTROL NUMBER	0ccccccc	c = CONTROL NUMBER
CONTROL VALUE	0vvvvvvv	v = DATA VALUE

(3-2-1) ALL SOUND OFF (CONTROL NUMBER = 78H , DATA VALUE = 0)

All the sounds currently played including the channel messages such as note-on and hold-on in a certain channel are muted when receiving this message.

(3-2-2) RESET ALL CONTROLLERS (CONTROL NUMBER = 79H , DATA VALUE = 0)

Resets the values set for the following controllers.

PITCH BEND CHANGE	0 (center)
MODULATION	0 (minimum)
EXPRESSION	127 (maximum)
SUSTAIN SWITCH	0 (off)

(3-2-3) ALL NOTE OFF (CONTROL NUMBER = 7BH , DATA VALUE = 0)

All the notes currently set to on in certain channel(s) are muted when receiving this message.
 However, if Sustain is on, notes will continue sounding until these are turned off.

(3-2-4) OMNI MODE OFF (CONTROL NUMBER = 7CH , DATA VALUE = 0)

Performs the same function as when receiving ALL NOTES OFF.
 Sets RECEIVE CHANNEL to channel 1.

(3-2-5) OMNI MODE ON (CONTROL NUMBER = 7DH , DATA VALUE = 0)

Performs the same function as when receiving ALL NOTES OFF.
 Sets RECEIVE CHANNEL to all.

(3-2-6) MONO (CONTROL NUMBER = 7EH , DATA VALUE = 0..16)

Performs the same function as when receiving ALL SOUNDS OFF.
 Sets MONO/POLY to mono-full.

(3-2-7) POLY (CONTROL NUMBER = 7FH , DATA VALUE = 0)

Performs the same function as when receiving ALL SOUNDS OFF.
 Sets MONO/POLY to poly.

(3-3) SYSTEM REAL TIME MESSAGES

(3-3-1) ACTIVE SENSING

STATUS	11111110 (FBH)
--------	----------------

Transmitted at every 200 msec.
 Once this code is received, the instrument starts sensing.
 When no status nor data is received for over approximately 350 ms, MIDI receiving buffer will be cleared, and the sounds currently played is forcibly turned off.

(3-3-2) TIMING CLOCK

STATUS	11111000 (FBH)
--------	----------------

When received via MIDI IN or USB-MIDI IN, the instrument automatically switches to external synchronization, to the internal clock.
 If no signal is received for 3 seconds, it switches back to the internal clock.

(3-3-3) START

STATUS	11111010 (FAH)
--------	----------------

(3-3-4) CONTINUE

STATUS	11111011 (FBH)
Receive only	

(3-3-5) STOP

STATUS	11111100 (FCH)
--------	----------------

(3-4) SYSTEM EXCLUSIVE MESSAGE

(3-4-1) UNIVERSAL NON REALTIME MESSAGE

(3-4-1-1) IDENTITY REQUEST (Receive only)

F0H 7EH 0nH 06H 01H F7H
 ("n" = Device No. However, this instrument receives under "omni.")

(3-4-1-2) IDENTITY REPLY (Transmit only)

F0H 7EH 7FH 06H 02H 43H 00H 41H 53H 06H 00H 00H 00H 7FH F7H

(3-4-2) PARAMETER CHANGE

11110000	F0H	Exclusive status
01000011	43H	YAMAHA ID
0001nnnn	1nH	Device Number
01111111	7FH	Group Number High
00011100	1CH	Group Number Low
00000101	05H	Model ID
0aaaaaaaa	aaaaaaaa	Address High
0aaaaaaaa	aaaaaaaa	Address Mid
0aaaaaaaa	aaaaaaaa	Address Low
0	0	Data
11110111	F7H	End of Exclusive

For parameters with data size of 2 or more, the appropriate number of data bytes will be transmitted.
 See the following MIDI Data Table for Address.

(3-4-3) BULK DUMP

11110000	F0H	Exclusive status
01000011	43H	YAMAHA ID
0001nnnn	0nH	Device Number
01111111	7FH	Group Number High
00011100	1CH	Group Number Low
0bbbbbbb	bbbbbbb	Byte Count
0bbbbbbb	bbbbbbb	Byte Count
00000101	05H	Model ID
0aaaaaaaa	aaaaaaaa	Address High
0aaaaaaaa	aaaaaaaa	Address Mid
0aaaaaaaa	aaaaaaaa	Address Low
0	0	Data
0ccccccc	ccccccc	Check-sum
11110111	F7H	End of Exclusive

See the following BULK DUMP Table for Address and Byte Count.
 Byte Count shows the size of data in blocks from Model ID onward (up to but not including the checksum).
 The Check sum is the value that results in a value of 0 for the lower 7 bits when the Model ID, Start Address, Data and Check sum itself are added.

(3-4-4) DUMP REQUEST

11110000	F0H	Exclusive status
01000011	43H	YAMAHA ID
0010nnnn	2nH	Device Number
01111111	7FH	Group Number High
00011100	1CH	Group Number Low
00000101	05H	Model ID
0aaaaaaaa	aaaaaaaa	Address High
0aaaaaaaa	aaaaaaaa	Address Mid
0aaaaaaaa	aaaaaaaa	Address Low
11110111	F7H	End of Exclusive

See the following DUMP REQUEST Table for Address and Byte Count.

(3-4-5) PARAMETER REQUEST

11110000	F0H	Exclusive status
01000011	43H	YAMAHA ID
0011nnnn	3nH	Device Number
01111111	7FH	Group Number High
00011100	1CH	Group Number Low
00000101	05H	Model ID
0aaaaaaaa	aaaaaaa	Address High
0aaaaaaaa	aaaaaaa	Address Mid
0aaaaaaaa	aaaaaaa	Address Low
11110111	F7H	End of Exclusive

See the following MIDI Data Table for Address.

(4) SYSTEM OVERVIEW (Keyboard (KBD), Looper Play/Rec (LPR PLAY/REC) and Tone Generator (TG))

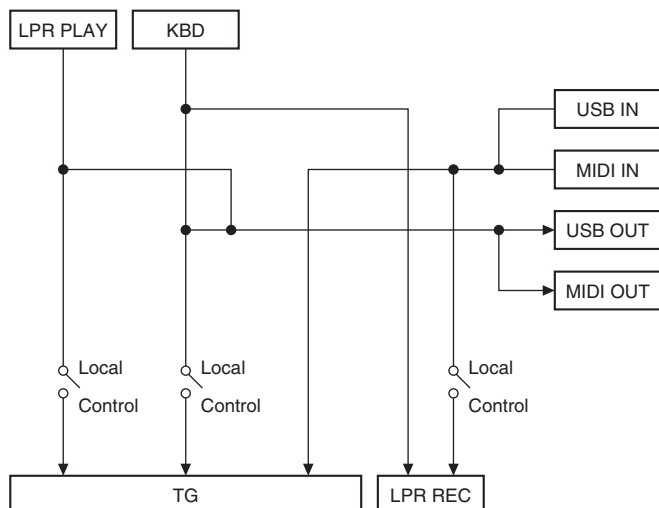

MIDI Data Table

Control Change

Transmitted and recognized Control Change Number and Value, when MIDI control is on.

Control Change Number		Control Value		Notes
Name	No.	Description	Transmitted	
ALGO (algorithm)	80	ALGO 1	0	0 - 11
		ALGO 2	12	12 - 21
		ALGO 3	23	22 - 32
		ALGO 4	35	33 - 42
		ALGO 5	46	43 - 53
		ALGO 6	58	54 - 64
		ALGO 7	69	65 - 74
		ALGO 8	81	75 - 85
		ALGO 9	92	86 - 95
		ALGO 10	104	96 - 106
		ALGO 11	115	107 - 116
		ALGO 12	127	117 - 127
OP1 LEVEL (output level)	85	—	0 - 127	0 - 127
OP1 FB (feedback level)	86	—	0 - 127	0 - 127
OP1 FB (feedback type)	87	sawtooth	0	0 - 63
		square	127	64 - 127
OP1 FREQ MODE	88	frequency/ratio (Ratio)	0	0 - 63
		fixed freq/Hz (Fixed)	127	64 - 127
OP1 FREQ RATIO/FREQ (coarse)	89	—	0 - 31	0 - 31
OP1 FREQ RATIO/FREQ (fine)	90	—	0 - 99	0 - 99
OP2 LEVEL (output level)	102	—	0 - 127	0 - 127
OP2 FB (feedback level)	103	—	0 - 127	0 - 127
OP2 FB (feedback type)	104	sawtooth	0	0 - 63
		square	127	64 - 127
OP2 FREQ MODE	105	frequency/ratio (Ratio)	0	0 - 63
		fixed freq/Hz (Fixed)	127	64 - 127
OP2 FREQ RATIO/FREQ (coarse)	106	—	0 - 31	0 - 31
OP2 FREQ RATIO/FREQ (fine)	107	—	0 - 99	0 - 99
OP3 LEVEL (output level)	108	—	0 - 127	0 - 127
OP3 FB (feedback level)	109	—	0 - 127	0 - 127
OP3 FB (feedback type)	110	sawtooth	0	0 - 63
		square	127	64 - 127
OP3 FREQ MODE	111	frequency/ratio (Ratio)	0	0 - 63
		fixed freq/Hz (Fixed)	127	64 - 127
OP3 FREQ RATIO/FREQ (coarse)	112	—	0 - 31	0 - 31
OP3 FREQ RATIO/FREQ (fine)	113	—	0 - 99	0 - 99
OP4 LEVEL (output level)	114	—	0 - 127	0 - 127
OP4 FB (feedback level)	115	—	0 - 127	0 - 127
OP4 FB (feedback type)	116	sawtooth	0	0 - 63
		square	127	64 - 127
OP4 FREQ MODE	117	frequency/ratio (Ratio)	0	0 - 63
		fixed freq/Hz (Fixed)	127	64 - 127
OP4 FREQ RATIO/FREQ (coarse)	118	—	0 - 31	0 - 31
OP4 FREQ RATIO/FREQ (fine)	119	—	0 - 99	0 - 99

Parameter Base Address

Parameter Block	Top Address (hex)			Description
	High	Mid	Low	
	SYSTEM	00	00	
VOICE COMMON	30	00	00	
VOICE OPERATOR	31	op	00	op: operator number (00 - 03)

Bulk Dump Block

"Top Address" indicates the top address of each block designated by bulk dump operation.

Byte Count shows the size of data in blocks from Model ID onward (up to but not including the checksum).

The Block from the Bulk Header to the Bulk Footer of the Voice can be received regardless their order.

They can be received even if all of them are not transmitted. They cannot be received if the irrelevant Block is included.

To carry out VOICE bulk dump request, designate its corresponding BulkHeader address.

Parameter Block	Description	Byte Count		Top Address (hex)			
		Dec	Hex	High	Mid	Low	
SYSTEM	Common	36	24	00	00	00	
VOICE	Bulk Header	4	04	0E	0F	00	
	COMMON	Voice Common	42	2A	30	00	00
	Operator	Operator 1	32	20	31	00	00
		:				:	
		Operator 4				03	
	Bulk Footer	4	04	0F	0F	00	

MIDI PARAMETER CHANGE TABLE (SYSTEM)

Address (hex)			Size	Data Range (hex)	Parameter Name	Description	Notes
High	Mid	Low					
00	00	00	1	00 - 0F, 7F	MIDI transmit channel (TR CH)	1 - 16, off	
		01	1	00 - 0F, 10	MIDI receive channel (RV CH)	1 - 16, All	
		02	4	00 - 00 00 - 07 00 - 0F 00 - 0F	Master Tune	-102.4 - +102.3 (cent) 1st bit 3-0 : bit 15- 12 2nd bit 3-0 : bit 11- 8 3rd bit 3-0 : bit 7- 4 4th bit 3-0 : bit 3- 0	
		06	1	00 - 01	Local Control (CONTROL)	off, ON	
		07	1	34 - 4C	Master Transpose	-12 - +12 (semitones)	
		08	2	00 - 02 00 - 7F	Tempo MSB Tempo LSB	30 - 300 1st bit 6-0 : bit 13-7 2nd bit 6-0 : bit 6-0	
		0A	1	00 - 3F	LCD Contrast (CONTRAST)	0 - 63	
		0B	1	00 - 01	Sustain Pedal Select (SUSTAIN)	FC3, FC4/5	
		0C	1	00 - 01	Auto Power-Off (AUTO P.OFF)	off, ON	
		0D	1	00 - 01	Speaker Output (SP)	off, ON	
		0E	1	00 - 01	MIDI Control (CONTROL)	off, ON	
		0F	1		reserved		
		10	1		reserved		
		11	1		reserved		
		12	1		reserved		
		13	1		reserved		
		14	1		reserved		
		15	1		reserved		
		16	1		reserved		
		17	1		reserved		
		18	1		reserved		
		19	1		reserved		
		1A	1		reserved		
		1B	1		reserved		
		1C	1		reserved		
		1D	1		reserved		
		1E	1		reserved		
		1F	1		reserved		

Total Size = 32

MIDI PARAMETER CHANGE TABLE (VOICE Common)

Address (hex)			Size	Data Range (hex)	Parameter Name	Description	Notes
High	Mid	Low					
30	00	00	1	20 - 7E	Voice Name1	32 - 126 (ASCII)	
		01	1	20 - 7E	Voice Name2	32 - 126 (ASCII)	
		02	1	20 - 7E	Voice Name3	32 - 126 (ASCII)	
		03	1	20 - 7E	Voice Name4	32 - 126 (ASCII)	
		04	1	20 - 7E	Voice Name5	32 - 126 (ASCII)	
		05	1	20 - 7E	Voice Name6	32 - 126 (ASCII)	
		06	1	20 - 7E	Voice Name7	32 - 126 (ASCII)	
		07	1	20 - 7E	Voice Name8	32 - 126 (ASCII)	
		08	1	20 - 7E	Voice Name9	32 - 126 (ASCII)	
		09	1	20 - 7E	Voice Name10	32 - 126 (ASCII)	
		0A	1		reserved		
		0B	1		reserved		
		0C	1	28 - 58	Transpose (TP)	-24 - +24 (semitones)	
		0D	1	00 - 02	Part Mode	poly (POLY), Mono-Full (MONO-FULL), Mono-Legato (MONO-LGATO)	MONO-FULL: applied to all notes MONO-LGATO: applied only to notes played legato
		0E	1	00 - 7F	Portamento Time (PORTA)		
		0F	1	28 - 58	Pitch Bend Range (PB)	-24 - +24 (semitones)	
		10	1	00 - 0B	Algorithm (ALGO)	ALGO 1 - 12	
		11	1	00 - 06	LFO Wave (WAVE)	sine (SIN), triangle (TRI), sawtooth up (SAW U), sawtooth down (SAW D), square (SQ), sample & hold 8 (S&H8), sample & hold (S&H)	
		12	1	00 - 7F	LFO Speed (SPEED)	0 - 127	
		13	1	00 - 7F	LFO Delay (DELAY)	0 - 127	
		14	1	00 - 7F	LFO Pitch Modulation Depth (PMD)	0 (no LFO) - 127 (max)	
		15	1	00 - 7F	Pitch EG Rate 1 (PITCH EG Rate)	0 (slow) - 127 (fast)	
		16	1	00 - 7F	Pitch EG Rate 2 (PITCH EG Rate)	0 (slow) - 127 (fast)	
		17	1	00 - 7F	Pitch EG Rate 3 (PITCH EG Rate)	0 (slow) - 127 (fast)	
		18	1	00 - 7F	Pitch EG Rate 4 (PITCH EG Rate)	0 (slow) - 127 (fast)	
		19	1	10 - 70	Pitch EG Level 1 (PITCH EG Level)	-48 (-4 octave) - +48 (+4 octave)	
		1A	1	10 - 70	Pitch EG Level 2 (PITCH EG Level)	-48 (-4 octave) - +48 (+4 octave)	
		1B	1	10 - 70	Pitch EG Level 3 (PITCH EG Level)	-48 (-4 octave) - +48 (+4 octave)	
		1C	1	10 - 70	Pitch EG Level 4 (PITCH EG Level)	-48 (-4 octave) - +48 (+4 octave)	
		1D	1	00 - 07	Effect 1 Type	thru (THRU), distortion (DIST), touch wah (T.WAH), chorus (CHO), flanger (FLA), phaser (PHA), delay (DLY), reverb (REV)	
		1E	1	00 - 7F	Effect 1 Parameter 1 (*Note)	0 - 127	DRIVE: distortion SENS: touch wah DEPTH: chorus, flanger, phaser, delay, reverb
		1F	1	00 - 7F	Effect 1 Parameter 2 (*Note)	0 - 127	TONE: distortion REZ: touch wah RATE: chorus, flanger, phaser TIME: delay, reverb
		20	1	00 - 07	Effect 2 Type	thru (THRU), distortion (DIST), touch wah (T.WAH), chorus (CHO), flanger (FLA), phaser (PHA), delay (DLY), reverb (REV)	
		21	1	00 - 7F	Effect 2 Parameter 1 (*Note)	0 - 127	DRIVE: distortion SENS: touch wah DEPTH: chorus, flanger, phaser, delay, reverb
		22	1	00 - 7F	Effect 2 Parameter 2 (*Note)	0 - 127	TONE: distortion REZ: touch wah RATE: chorus, flanger, phaser TIME: delay, reverb
		23	3		reserved		

Total Size = 38

MIDI PARAMETER CHANGE TABLE (Operator)

op = operator number
00 - 03 (hex)
OP1 - OP4

Address (hex)			Size	Data Range (hex)	Parameter Name	Description	Notes
High	Mid	Low					
31	op	00	1	00 - 01	OP ON-OFF (OP)	off, ON	
	op	01	1	00 - 7F	OP EG Rate 1	0 (slow) - 127 (fast)	
	op	02	1	00 - 7F	OP EG Rate 2	0 (slow) - 127 (fast)	
	op	03	1	00 - 7F	OP EG Rate 3	0 (slow) - 127 (fast)	
	op	04	1	00 - 7F	OP EG Rate 4	0 (slow) - 127 (fast)	
	op	05	1	00 - 7F	OP EG Level 1	0 (no output) - 127 (max)	
	op	06	1	00 - 7F	OP EG Level 2	0 (no output) - 127 (max)	
	op	07	1	00 - 7F	OP EG Level 3	0 (no output) - 127 (max)	
	op	08	1	00 - 7F	OP EG Level 4	0 (no output) - 127 (max)	
	op	09	1	00 - 7F	OP EG Keyboard Rate Scaling (KSC-R)	0 - 127	
	op	0A	1	00 - 7F	OP Keyboard Level Scaling Left Depth (KSC-Level)	0 (flat: no variation) - 127 (max)	
	op	0B	1	00 - 7F	OP Keyboard Level Scaling Right Depth (KSC-Level)	0 (flat: no variation) - 127 (max)	
	op	0C	1	00 - 03	OP Keyboard Level Scaling Left Curve (KSC-Level)	-linear (-LIN), -exponential (-EXP), +exponential (+EXP), +linear (+LIN)	
	op	0D	1	00 - 03	OP Keyboard Level Scaling Right Curve (KSC-Level)	-linear (-LIN), -exponential (-EXP), +exponential (+EXP), +linear (+LIN)	
	op	0E	1	00 - 7F	OP LFO AMD Depth (LFO AMD)	0 (no amplitude) - 127 (max)	
	op	0F	1	00 - 01	OP LFO PMD ON/OFF (LFO PMD On/Off)	off, ON	
	op	10	1	00 - 01	OP PEG ON/OFF (PITCH EG On/Off)	off, ON	
	op	11	1	00 - 7F	OP Level Velocity Sensitivity (VEL.S)	0 (no touch response) - 127 (max)	
	op	12	1	00 - 7F	OP Level Output Level (LEVEL)	0 - 127	
	op	13	1	00 - 7F	OP Level Feedback Level (FB)	0 - 127	
	op	14	1	00 - 01	OP Level Feedback Type (FB)	sawtooth, square	
	op	15	1	00 - 01	OP Freq. Mode (MODE)	frequency/ratio (Ratio), fixed freq/Hz (Fixed)	
	op	16	1	00 - 1F	OP Freq. Coarse (RATIO/FREQ)		
	op	17	1	00 - 63	OP Freq. Fine (RATIO/FREQ)		
	op	18	1	00 - 7F	OP Freq. Detune (DTUNE)	-64 - +63	
	op	19	3		reserved		

Total Size = 28

Program Change Number

Program No.	Description	Notes
0 - 7	Bank 1-1 - 1-8	
8 - 15	Bank 2-1 - 2-8	
16 - 23	Bank 3-1 - 3-8	
24 - 31	Bank 4-1 - 4-8	

MIDI Implementation Chart

YAMAHA [Mobile Mini Keyboard]
Model reface DX MIDI Implementation Chart

Date :20-FEB-2015
Version : 1.0

Function...	Transmitted	Recognized	Remarks	
Basic Channel	Default Changed	1 1 - 16	1 - 16 1 - 16	Memorized
Mode	Default Messages Altered	3 x *****	1 1 - 4 (m=1) *2 x	
Note Number : True voice	24 - 108 *****	0 - 127 0 - 127	Transpose	
Velocity	Note ON Note OFF	o 9nH,v=1-127 x 9nH,v=0	o v=1-127 x	
After Touch	Key's Ch's	x x	x x	
Pitch Bend		o	o	
Control Change	1 7 11 64 80,85-90 102-119	x x x o o *1 o *1	o o o o o *1 o *1	Modulation Wheel Main Volume Expression Sustain Sw
Prog Change : True #	o 0 - 31 *****	o 0 - 31 0 - 31		
System Exclusive		o	o	
Common : Song Pos. : Song Sel. : Tune	x x x	x x x		
System : Clock Real Time : Commands	o o	o o		
Aux : All Sound Off : Reset All Cntrls : Local ON/OFF Mes- : All Notes OFF sages: Active Sense : Reset	x x x x o x	o (120,126,127) o (121) x o (123-125) o x		
Notes:*1 Transmitted and recognized if MIDI control mode is on. *2 "m" is always treated as "1" regardless of its actual value.				

Mode 1 : OMNI ON , POLY
Mode 3 : OMNI OFF, POLY

Mode 2 : OMNI ON ,MONO
Mode 4 : OMNI OFF,MONO

o : Yes
x : No

MIDI Data Format

(1) Coverage

The specifications described herein specify transmission and reception of MIDI data of the reface CP.

(2) Compliance

The specifications described herein comply to the following standards:
• MIDI 1.0

(3) TRANSMIT/RECEIVE DATA

(3-1) CHANNEL VOICE MESSAGES

(3-1-1) NOTE OFF

STATUS	1000nnnn (8nH)	n = 0 - 15 CHANNEL NUMBER
NOTE No.	0kkkkkkk	k = 0 (C-2) - 127 (G8)
VELOCITY	0vvvvvvv	v: ignored

Receive only

(3-1-2) NOTE ON/OFF

STATUS	1001nnnn (9nH)	n = 0 - 15 CHANNEL NUMBER
NOTE NUMBER	0kkkkkkk	k = 0 (C-2) - 127 (G8)
VELOCITY	NOTE ON 0vvvvvvv (v≠0) NOTE OFF 0vvvvvvv (v=0)	

(3-1-3) CONTROL CHANGE

STATUS	1011nnnn (BnH)	n = 0 - 15 CHANNEL NUMBER
CONTROL NUMBER	0ccccccc	c = 0 - 127
CONTROL VALUE	0vvvvvvv	v = 0 - 127

*TRANSMITTED CONTROL NUMBER
c = 64 SUSTAIN SWITCH ; v = 0 - 127 *1

*1 When Sustain is set to "FC4/5," operating the foot switch transmits only values of 0 (off) or 127 (on).

*RECEIVED CONTROL NUMBER

c = 1	MODULATION	; v = 0 - 127
c = 7	VOLUME	; v = 0 - 127
c = 11	EXPRESSION	; v = 0 - 127
c = 64	SUSTAIN SWITCH	; v = 0 - 127
c = 66	SOSTENUTO	; v = 0-63:OFF , 64-127:ON
c = 67	SOFT PEDAL	; v = 0-63:OFF , 64-127:ON

When MIDI Control Mode is turned on, Control Change numbers are assigned in order that voice parameter changes made using controllers on the front panel can be controlled via MIDI.
See the following Control Change Table.

(3-1-4) PITCH BEND CHANGE (Receive only)

STATUS	1110nnnn (EnH)	n = 0 - 15 CHANNEL NUMBER
LSB	0vvvvvvv	PITCH BEND CHANGE LSB
MSB	0vvvvvvv	PITCH BEND CHANGE MSB

(3-2) CHANNEL MODE MESSAGES

STATUS	1011nnnn (BnH)	n = 0 - 15 CHANNEL NUMBER
CONTROL NUMBER	0ccccccc	c = CONTROL NUMBER
CONTROL VALUE	0vvvvvvv	v = DATA VALUE

(3-2-1) ALL SOUND OFF (CONTROL NUMBER = 78H , DATA VALUE = 0)

All the sounds currently played including the channel messages such as note-on and hold-on in a certain channel are muted when receiving this message.

(3-2-2) RESET ALL CONTROLLERS (CONTROL NUMBER = 79H , DATA VALUE = 0)

Resets the values set for the following controllers.

PITCH BEND CHANGE	0 (center)
MODULATION	0 (minimum)
EXPRESSION	127 (maximum)
SUSTAIN SWITCH	0 (off)
SOSTENUTO SWITCH	0 (off)
SOFT PEDAL	0 (off)

(3-2-3) ALL NOTE OFF (CONTROL NUMBER = 7BH , DATA VALUE = 0)

All the notes currently set to on in certain channel(s) are muted when receiving this message.
However, if Sustain or Sostenuto is on, notes will continue sounding until these are turned off.

(3-2-4) OMNI MODE OFF (CONTROL NUMBER = 7CH , DATA VALUE = 0)

Performs the same function as when receiving ALL NOTES OFF.
Sets RECEIVE CHANNEL to channel 1.

(3-2-5) OMNI MODE ON (CONTROL NUMBER = 7DH , DATA VALUE = 0)

Performs the same function as when receiving ALL NOTES OFF.
Sets RECEIVE CHANNEL to all.

(3-2-6) MONO (CONTROL NUMBER = 7EH , DATA VALUE = 0..16)

Performs the same function as when receiving ALL SOUNDS OFF.

(3-2-7) POLY (CONTROL NUMBER = 7FH , DATA VALUE = 0)

Performs the same function as when receiving ALL SOUNDS OFF.

(3-3) SYSTEM REAL TIME MESSAGES

(3-3-1) ACTIVE SENSING

STATUS	11111110 (FBH)
--------	----------------

Transmitted at every 200 msec.

Once this code is received, the instrument starts sensing.

When no status nor data is received for over approximately 350 ms, MIDI receiving buffer will be cleared, and the sounds currently played is forcibly turned off.

(3-4) SYSTEM EXCLUSIVE MESSAGE

(3-4-1) UNIVERSAL NON REALTIME MESSAGE

(3-4-1-1) IDENTITY REQUEST (Receive only)

F0H 7EH 0nH 06H 01H F7H

("n" = Device No. However, this instrument receives under "omni.")

(3-4-1-2) IDENTITY REPLY (Transmit only)

F0H 7EH 7FH 06H 02H 43H 00H 41H 52H 06H 00H 00H 00H 7FH F7H

(3-4-2) PARAMETER CHANGE

11110000	F0H	Exclusive status
01000011	43H	YAMAHA ID
0001nnnn	1nH	Device Number
01111111	7FH	Group Number High
00011100	1CH	Group Number Low
00000100	04H	Model ID
0aaaaaaa	aaaaaaa	Address High
0aaaaaaa	aaaaaaa	Address Mid
0aaaaaaa	aaaaaaa	Address Low
0ddddddd	ddddddd	Data
11110111	F7H	End of Exclusive

For parameters with data size of 2 or more, the appropriate number of data bytes will be transmitted.
See the following MIDI Data Table for Address.

(3-4-3) BULK DUMP

11110000	F0H	Exclusive status
01000011	43H	YAMAHA ID
0000nnnn	0nH	Device Number
01111111	7FH	Group Number High
00011100	1CH	Group Number Low
0bbbbbbb	bbbbbbb	Byte Count
0bbbbbbb	bbbbbbb	Byte Count
00000100	04H	Model ID
0aaaaaaa	aaaaaaa	Address High
0aaaaaaa	aaaaaaa	Address Mid
0aaaaaaa	aaaaaaa	Address Low
0	0	Data
0ccccccc	ccccccc	Check-sum
11110111	F7H	End of Exclusive

See the following BULK DUMP Table for Address and Byte Count.
Byte Count shows the size of data in blocks from Model ID onward (up to but not including the checksum).
The Check sum is the value that results in a value of 0 for the lower 7 bits when the Model ID, Start Address, Data and Check sum itself are added.

(3-4-4) DUMP REQUEST

11110000	F0H	Exclusive status
01000011	43H	YAMAHA ID
0010nnnn	2nH	Device Number
01111111	7FH	Group Number High
00011100	1CH	Group Number Low
00000100	04H	Model ID
0aaaaaaa	aaaaaaa	Address High
0aaaaaaa	aaaaaaa	Address Mid
0aaaaaaa	aaaaaaa	Address Low
11110111	F7H	End of Exclusive

See the following DUMP REQUEST Table for Address and Byte Count.

(3-4-5) PARAMETER REQUEST

11110000	F0H	Exclusive status
01000011	43H	YAMAHA ID
0011nnnn	3nH	Device Number
01111111	7FH	Group Number High
00011100	1CH	Group Number Low
00000100	04H	Model ID
0aaaaaaa	aaaaaaa	Address High
0aaaaaaa	aaaaaaa	Address Mid
0aaaaaaa	aaaaaaa	Address Low
11110111	F7H	End of Exclusive

See the following MIDI Data Table for Address.

(4) SYSTEM OVERVIEW (Keyboard (KBD), and
Tone Generator (TG))

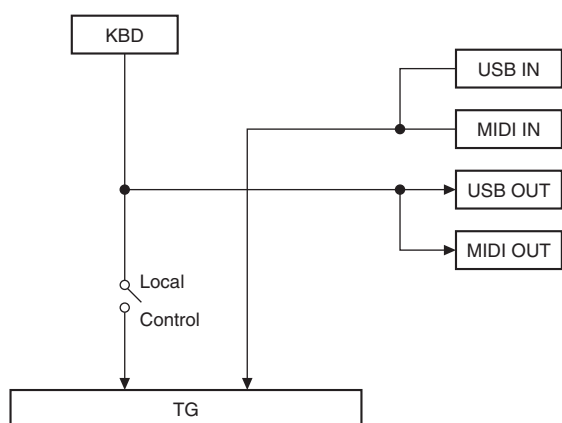

MIDI Data Table

Control Change

Transmitted and recognized Control Change Number and Value, when MIDI control is on.

Control Change Number			Control Value		Notes
Name	No.	Description	Transmitted	Recognized	
TYPE	80	Rd I	0	0 – 21	
		Rd II	25	22 – 42	
		Wr	51	43 – 64	
		Clv	76	65 – 85	
		Toy	102	86 – 106	
		CP	127	107 – 127	
DRIVE	81	—	0 – 127	0 – 127	
TREMOLO/WAH SWITCH	17	OFF	0	0 – 42	
		TREMOLO	64	43 – 85	
		WAH	127	86 – 127	
		—	—	—	
TREMOLO/WAH DEPTH	18	—	0 – 127	0 – 127	
TREMOLO/WAH RATE	19	—	0 – 127	0 – 127	
CHORUS/PHASER SWITCH	85	OFF	0	0 – 42	
		CHORUS	64	43 – 85	
		PHASER	127	86 – 127	
CHORUS/PHASER DEPTH	86	—	0 – 127	0 – 127	
CHORUS/PHASER SPEED	87	—	0 – 127	0 – 127	
D.DELAY/A.DELAY SWITCH	88	OFF	0	0 – 42	
		D.DELAY	64	43 – 85	
		A.DELAY	127	86 – 127	
D.DELAY/A.DELAY DEPTH	89	—	0 – 127	0 – 127	
D.DELAY/A.DELAY TIME	90	—	0 – 127	0 – 127	
REVERB DEPTH	91	—	0 – 127	0 – 127	

Parameter Base Address

Parameter Block	Top Address (hex)			Description
	High	Mid	Low	
	SYSTEM	00	00	
TG	30	00	00	

Bulk Dump Block

"Top Address" indicates the top address of each block designated by bulk dump operation.

Byte Count shows the size of data in blocks from Model ID onward (up to but not including the checksum).

To carry out TG bulk dump request, designate its corresponding BulkHeader address.

Parameter Block	Description	Byte Count		Top Address (hex)			
		Dec	Hex	High	Mid	Low	
SYSTEM	Common	36	24	00	00	00	
TG	Bulk Header	4	04	0E	0F	00	
	COMMON	TG Common	20	14	30	00	00
	Bulk Footer	4	04	0F	0F	00	

MIDI PARAMETER CHANGE TABLE (SYSTEM)

Address (hex)			Size	Data Range (hex)	Parameter Name	Description	Notes
High	Mid	Low					
00	00	00	1	00 – 0F, 7F	MIDI transmit channel	1 – 16, off	
		01	1	00 – 0F, 10	MIDI receive channel	1 – 16, All	
		02	4	00 – 00 00 – 07 00 – 0F 00 – 0F	Master Tune	-102.4 – +102.3 (cent) 1st bit 3-0 : bit 15- 12 2nd bit 3-0 : bit 11- 8 3rd bit 3-0 : bit 7- 4 4th bit 3-0 : bit 3- 0	
		06	1	00 – 01	Local Control	off, ON	
		07	1	34 – 4C	Master Transpose	-12 – +12 (semitones)	
		08	1		reserved		
		09	1		reserved		
		0A	1		reserved		
		0B	1	00 – 01	Sustain Pedal Select	FC3, FC4/5	
		0C	1	00 – 01	Auto Power-Off	off, ON	
		0D	1	00 – 01	Speaker Output	off, ON	
		0E	1	00 – 01	MIDI Control	off, ON	
		0F	1		reserved		
		10	1		reserved		
		11	1		reserved		
		12	1		reserved		
		13	1		reserved		
		14	1		reserved		
		15	1		reserved		
		16	1		reserved		
		17	1		reserved		
		18	1		reserved		
		19	1		reserved		
		1A	1		reserved		
		1B	1		reserved		
		1C	1		reserved		
		1D	1		reserved		
		1E	1		reserved		
		1F	1		reserved		

Total Size = 32

MIDI PARAMETER CHANGE TABLE (Tone Generator)

Address (hex)			Size	Data Range (hex)	Parameter Name	Description	Notes
High	Mid	Low					
30	00	00	1	00 – 7F	Volume	0 – 127	This parameter can be set only via MIDI.
		01	1		reserved		
		02	1	00 – 05	Wave Type (TYPE)	Rd I, Rd II, Wr, Clv, Toy, CP	
		03	1	00 – 7F	Drive (DRIVE)	0 – 127	
		04	1	00 – 02	Effect 1 Type (TREMOLO/WAH)	thru (middle position), tremolo (TREMOLO), wah (WAH)	
		05	1	00 – 7F	Effect 1 Depth (DEPTH)	0 – 127	Rd I, Rd II, CP: sound is modulated left and right Wr, Clv, Toy: volume is modulated
		06	1	00 – 7F	Effect 1 Rate (RATE)	0 – 127	TREMOLO: speed of modulation WAH: resonance offset value
		07	1	00 – 02	Effect 2 Type (CHORUS/PHASER)	thru (middle position), chorus (CHORUS), phaser (PHASER)	
		08	1	00 – 7F	Effect 2 Depth (DEPTH)	0 – 127	
		09	1	00 – 7F	Effect 2 Speed (SPEED)	0 – 127	
		0A	1	00 – 02	Effect 3 Type (D.DELAY/A.DELAY)	thru (middle position), Digital Delay (D.DELAY), Analog Delay (A.DELAY)	
		0B	1	00 – 7F	Effect 3 Depth (DEPTH)	0 – 127	
		0C	1	00 – 7F	Effect 3 Time (TIME)	0 – 127	
		0D	1	00 – 7F	Reverb Depth (REVERB DEPTH)	0 – 127	
		0E	2		reserved		

Total Size = 16

MIDI Implementation Chart

YAMAHA [Mobile Mini Keyboard]
Model reface CP MIDI Implementation Chart

Date :23-MAR-2015
Version : 1.0

Function...	Transmitted	Recognized	Remarks	
Basic Channel	Default Changed	1 1 - 16	1 - 16 1 - 16	
Mode	Default Messages Altered	3 x *****	1 1,3 x	
Note Number : True voice	24 - 108 *****	0 - 127 0 - 127	Transpose	
Velocity	Note ON Note OFF	o 9nH,v=1-127 x 9nH,v=0	o v=1-127 x	
After Touch	Key's Ch's	x x	x x	
Pitch Bend		x	o	
Control	1 7 11 64 66,67	x x x o x	o o o o o	Modulation Wheel Main Volume Expression Sustain Sw
Change	17-19 80,81 85-91	o *1 o *1 o *1	o *1 o *1 o *1	
Prog Change : True #	x *****	x x		
System Exclusive		o	o	
Common : Song Pos. : Song Sel. : Tune	x x x	x x x		
System : Clock Real Time : Commands	x x	x x		
Aux : All Sound Off : Reset All Cntrls : Local ON/OFF Mes- : All Notes OFF sages: Active Sense : Reset	x x x x o x	o (120,126,127) o (121) x o (123-125) o x		
Notes:*1 Transmitted and recognized if MIDI control mode is on.				

Mode 1 : OMNI ON , POLY
Mode 3 : OMNI OFF, POLY

Mode 2 : OMNI ON ,MONO
Mode 4 : OMNI OFF,MONO

o : Yes
x : No

MIDI Data Format

(1) Coverage

The specifications described herein specify transmission and reception of MIDI data of the reface YC.

(2) Compliance

The specifications described herein comply to the following standards:
• MIDI 1.0

(3) TRANSMIT/RECEIVE DATA

(3-1) CHANNEL VOICE MESSAGES

(3-1-1) NOTE OFF

STATUS	100nnnn (8nH)	n = 0 - 15 CHANNEL NUMBER
NOTE No.	0kkkkkkk	k = 0 (C-2) - 127 (G8)
VELOCITY	0vvvvvvv	v: ignored

Receive only

(3-1-2) NOTE ON/OFF

STATUS	100lnnnn (9nH)	n = 0 - 15 CHANNEL NUMBER
NOTE NUMBER	0kkkkkkk	k = 0 (C-2) - 127 (G8)
VELOCITY	NOTE ON 0vvvvvvv (v≠0)	
	NOTE OFF 0vvvvvvv (v=0)	

(3-1-3) CONTROL CHANGE

STATUS	101lnnnn (8nH)	n = 0 - 15 CHANNEL NUMBER
CONTROL NUMBER	0ccccccc	
CONTROL VALUE	0vvvvvvv	

*TRANSMITTED CONTROL NUMBER
c = 11 EXPRESSION ; v = 0 - 127

*RECEIVED CONTROL NUMBER
c = 1 MODULATION ; v = 0 - 127
c = 7 VOLUME ; v = 0 - 127
c = 11 EXPRESSION ; v = 0 - 127
c = 64 SUSTAIN SWITCH ; v = 0 - 127

When MIDI Control Mode is turned on, Control Change numbers are assigned in order that voice parameter changes made using controllers on the front panel can be controlled via MIDI.
See the following Control Change Table.

(3-1-4) PITCH BEND CHANGE (Receive only)

STATUS	110nnnn (EnH)	n = 0 - 15 CHANNEL NUMBER
LSB	0vvvvvvv	PITCH BEND CHANGE LSB
MSB	0vvvvvvv	PITCH BEND CHANGE MSB

(3-2) CHANNEL MODE MESSAGES

STATUS	101lnnnn (8nH)	n = 0 - 15 CHANNEL NUMBER
CONTROL NUMBER	0ccccccc	c = CONTROL NUMBER
CONTROL VALUE	0vvvvvvv	v = DATA VALUE

(3-2-1) ALL SOUND OFF (CONTROL NUMBER = 78H , DATA VALUE = 0)

All the sounds currently played including the channel messages such as note-on and hold-on in a certain channel are muted when receiving this message.

(3-2-2) RESET ALL CONTROLLERS (CONTROL NUMBER = 79H , DATA VALUE = 0)

Resets the values set for the following controllers.

PITCH BEND CHANGE	0 (center)
MODULATION	0 (minimum)
EXPRESSION	127 (maximum)
SUSTAIN SWITCH	0 (off)

(3-2-3) ALL NOTE OFF (CONTROL NUMBER = 7BH , DATA VALUE = 0)

All the notes currently set to on in certain channel(s) are muted when receiving this message.
However, if Sustain is on, notes will continue sounding until these are turned off.

(3-2-4) OMNI MODE OFF (CONTROL NUMBER = 7CH , DATA VALUE = 0)

Performs the same function as when receiving ALL NOTES OFF.
Sets RECEIVE CHANNEL to channel 1.

(3-2-5) OMNI MODE ON (CONTROL NUMBER = 7DH , DATA VALUE = 0)

Performs the same function as when receiving ALL NOTES OFF.
Sets RECEIVE CHANNEL to all.

(3-2-6) MONO (CONTROL NUMBER = 7EH , DATA VALUE = 0..16)

Performs the same function as when receiving ALL SOUNDS OFF.

(3-2-7) POLY (CONTROL NUMBER = 7FH , DATA VALUE = 0)

Performs the same function as when receiving ALL SOUNDS OFF.

(3-3) SYSTEM REAL TIME MESSAGES

(3-3-1) ACTIVE SENSING

STATUS	11111110 (FBH)
--------	----------------

Transmitted at every 200 msec.

Once this code is received, the instrument starts sensing.

When no status nor data is received for over approximately 350 ms, MIDI receiving buffer will be cleared, and the sounds currently played is forcibly turned off.

(3-4) SYSTEM EXCLUSIVE MESSAGE

(3-4-1) UNIVERSAL NON REALTIME MESSAGE

(3-4-1-1) IDENTITY REQUEST (Receive only)

F0H 7EH 0nH 06H 01H F7H

("n" = Device No. However, this instrument receives under "omni.")

(3-4-1-2) IDENTITY REPLY (Transmit only)

F0H 7EH 7FH 06H 02H 43H 00H 41H 54H 06H 00H 00H 00H 7FH F7H

(3-4-2) PARAMETER CHANGE

11110000	F0H	Exclusive status
01000011	43H	YAMAHA ID
0001nnnn	1nH	Device Number
01111111	7FH	Group Number High
00011100	1CH	Group Number Low
00000110	06H	Model ID
0aaaaaaa	aaaaaaa	Address High
0aaaaaaa	aaaaaaa	Address Mid
0aaaaaaa	aaaaaaa	Address Low
0ddddd	ddddd	Data
11110111	F7H	End of Exclusive

For parameters with data size of 2 or more, the appropriate number of data bytes will be transmitted.
See the following MIDI Data Table for Address.

(3-4-3) BULK DUMP

11110000	F0H	Exclusive status
01000011	43H	YAMAHA ID
0000nnnn	0nH	Device Number
01111111	7FH	Group Number High
00011100	1CH	Group Number Low
0bbbbbbb	bbbbbbb	Byte Count
0bbbbbbb	bbbbbbb	Byte Count
00000110	06H	Model ID
0aaaaaaa	aaaaaaa	Address High
0aaaaaaa	aaaaaaa	Address Mid
0aaaaaaa	aaaaaaa	Address Low
0	0	Data
0ccccccc	ccccccc	Check-sum
11110111	F7H	End of Exclusive

See the following BULK DUMP Table for Address and Byte Count.
Byte Count shows the size of data in blocks from Model ID onward (up to but not including the checksum).
The Check sum is the value that results in a value of 0 for the lower 7 bits when the Model ID, Start Address, Data and Check sum itself are added.

(3-4-4) DUMP REQUEST

11110000	F0H	Exclusive status
01000011	43H	YAMAHA ID
0010nnnn	2nH	Device Number
01111111	7FH	Group Number High
00011100	1CH	Group Number Low
00000110	06H	Model ID
0aaaaaaa	aaaaaaa	Address High
0aaaaaaa	aaaaaaa	Address Mid
0aaaaaaa	aaaaaaa	Address Low
11110111	F7H	End of Exclusive

See the following DUMP REQUEST Table for Address and Byte Count.

(3-4-5) PARAMETER REQUEST

11110000	F0H	Exclusive status
01000011	43H	YAMAHA ID
0011nnnn	3nH	Device Number
01111111	7FH	Group Number High
00011100	1CH	Group Number Low
00000110	06H	Model ID
0aaaaaaa	aaaaaaa	Address High
0aaaaaaa	aaaaaaa	Address Mid
0aaaaaaa	aaaaaaa	Address Low
11110111	F7H	End of Exclusive

See the following MIDI Data Table for Address.

(4) SYSTEM OVERVIEW (Keyboard (KBD), and
Tone Generator (TG))

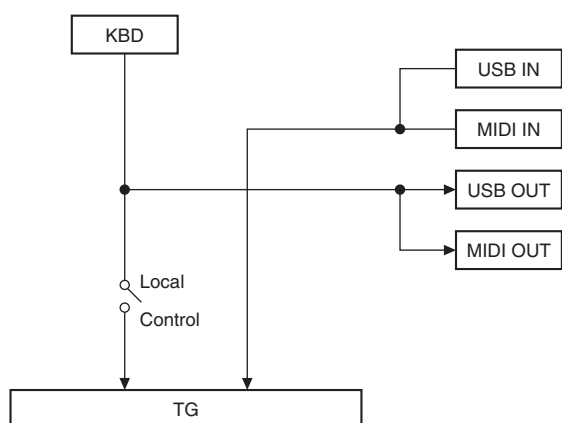

MIDI Data Table

Control Change

Transmitted and recognized Control Change Number and Value, when MIDI control is on.

Control Change Number			Control Value		Notes
Name	No.	Description	Transmitted	Recognized	
ROTARY SPEED	19	OFF	0	0 – 32	
		STOP	42	33 – 64	
		SLOW	85	65 – 95	
		FAST	127	96 – 127	
WAVE	80	H	0	0 – 25	
		V	32	26 – 51	
		F	64	52 – 76	
		A	95	77 – 102	
		Y	127	103 – 127	
FOOTAGE 16'	102	FOOTAGE Slider 0 (Minimum: up)	0	0 – 18	
		FOOTAGE Slider 1	21	19 – 36	
		FOOTAGE Slider 2	42	37 – 54	
		FOOTAGE Slider 3	64	55 – 73	
		FOOTAGE Slider 4	85	74 – 91	
		FOOTAGE Slider 5	106	92 – 109	
		FOOTAGE Slider 6 (Maximum)	127	110 – 127	
FOOTAGE 5 1/3'	103	FOOTAGE Slider 0 (Minimum: up)	0	0 – 18	
		FOOTAGE Slider 1	21	19 – 36	
		FOOTAGE Slider 2	42	37 – 54	
		FOOTAGE Slider 3	64	55 – 73	
		FOOTAGE Slider 4	85	74 – 91	
		FOOTAGE Slider 5	106	92 – 109	
		FOOTAGE Slider 6 (Maximum)	127	110 – 127	
FOOTAGE 8'	104	FOOTAGE Slider 0 (Minimum: up)	0	0 – 18	
		FOOTAGE Slider 1	21	19 – 36	
		FOOTAGE Slider 2	42	37 – 54	
		FOOTAGE Slider 3	64	55 – 73	
		FOOTAGE Slider 4	85	74 – 91	
		FOOTAGE Slider 5	106	92 – 109	
		FOOTAGE Slider 6 (Maximum)	127	110 – 127	
FOOTAGE 4'	105	FOOTAGE Slider 0 (Minimum: up)	0	0 – 18	
		FOOTAGE Slider 1	21	19 – 36	
		FOOTAGE Slider 2	42	37 – 54	
		FOOTAGE Slider 3	64	55 – 73	
		FOOTAGE Slider 4	85	74 – 91	
		FOOTAGE Slider 5	106	92 – 109	
		FOOTAGE Slider 6 (Maximum)	127	110 – 127	
FOOTAGE 2 2/3'	106	FOOTAGE Slider 0 (Minimum: up)	0	0 – 18	
		FOOTAGE Slider 1	21	19 – 36	
		FOOTAGE Slider 2	42	37 – 54	
		FOOTAGE Slider 3	64	55 – 73	
		FOOTAGE Slider 4	85	74 – 91	
		FOOTAGE Slider 5	106	92 – 109	
		FOOTAGE Slider 6 (Maximum)	127	110 – 127	
FOOTAGE 2'	107	FOOTAGE Slider 0 (Minimum: up)	0	0 – 18	
		FOOTAGE Slider 1	21	19 – 36	
		FOOTAGE Slider 2	42	37 – 54	
		FOOTAGE Slider 3	64	55 – 73	
		FOOTAGE Slider 4	85	74 – 91	
		FOOTAGE Slider 5	106	92 – 109	
		FOOTAGE Slider 6 (Maximum)	127	110 – 127	
FOOTAGE 1 3/5'	108	FOOTAGE Slider 0 (Minimum: up)	0	0 – 18	
		FOOTAGE Slider 1	21	19 – 36	
		FOOTAGE Slider 2	42	37 – 54	
		FOOTAGE Slider 3	64	55 – 73	
		FOOTAGE Slider 4	85	74 – 91	
		FOOTAGE Slider 5	106	92 – 109	
		FOOTAGE Slider 6 (Maximum)	127	110 – 127	
FOOTAGE 1 1/3'	109	FOOTAGE Slider 0 (Minimum: up)	0	0 – 18	
		FOOTAGE Slider 1	21	19 – 36	
		FOOTAGE Slider 2	42	37 – 54	
		FOOTAGE Slider 3	64	55 – 73	
		FOOTAGE Slider 4	85	74 – 91	
		FOOTAGE Slider 5	106	92 – 109	
		FOOTAGE Slider 6 (Maximum)	127	110 – 127	

Control Change Number			Control Value		Notes
Name	No.	Description	Transmitted	Recognized	
FOOTAGE 1'	110	FOOTAGE Slider 0 (Minimum: up)	0	0 – 18	
		FOOTAGE Slider 1	21	19 – 36	
		FOOTAGE Slider 2	42	37 – 54	
		FOOTAGE Slider 3	64	55 – 73	
		FOOTAGE Slider 4	85	74 – 91	
		FOOTAGE Slider 5	106	92 – 109	
		FOOTAGE Slider 6 (Maximum)	127	110 – 127	
VIBRATO/CHORUS SWITCH	79	VIBRATO	0	0 – 63	
		CHORUS	127	64 – 127	
VIBRATO/CHORUS DEPTH	77	0 (Minimum)	0	0 – 25	
		1	32	26 – 51	
		2	64	52 – 76	
		3	95	77 – 102	
		4 (Maximum: up)	127	103 – 127	
PERCUSSION ON/OFF SWITCH	111	OFF	0	0 – 63	
		ON	127	64 – 127	
PERCUSSION TYPE SWITCH	112	A	0	0 – 63	
		B	127	64 – 127	
PERCUSSION LENGTH	113	0 (Minimum)	0	0 – 25	
		1	32	26 – 51	
		2	64	52 – 76	
		3	95	77 – 102	
		4 (Maximum: up)	127	103 – 127	
EFFECT DIST	18	—	0 – 127	0 – 127	
EFFECT REVERB	91	—	0 – 127	0 – 127	

Parameter Base Address

Parameter Block	Top Address (hex)			Description
	High	Mid	Low	
	SYSTEM	00	00	
TG	30	00	00	

Bulk Dump Block

“Top Address” indicates the top address of each block designated by bulk dump operation.

Byte Count shows the size of data in blocks from Model ID onward (up to but not including the checksum).

To carry out TG bulk dump request, designate its corresponding BulkHeader address.

Parameter Block	Description	Byte Count		Top Address (hex)		
		Dec	Hex	High	Mid	Low
SYSTEM	Common	36	24	00	00	00
TG	Bulk Header	4	04	0E	0F	00
	COMMON	26	1A	30	00	00
	Bulk	4	04	0F	0F	00

MIDI PARAMETER CHANGE TABLE (SYSTEM)

Address (hex)			Size	Data Range (hex)	Parameter Name	Description	Notes
High	Mid	Low					
00	00	00	1	00 - 0F, 7F	MIDI transmit channel	1 - 16, off	
		01	1	00 - 0F, 10	MIDI receive channel	1 - 16, All	
		02	4	00 - 00 00 - 07 00 - 0F 00 - 0F	Master Tune	-102.4 - +102.3 (cent) 1st bit 3-0 : bit 15- 12 2nd bit 3-0 : bit 11- 8 3rd bit 3-0 : bit 7- 4 4th bit 3-0 : bit 3- 0	
		06	1	00 - 01	Local Control	off, ON	
		07	1	34 - 4C	Master Transpose	-12 - +12 (semitones)	
		08	1		reserved		
		09	1		reserved		
		0A	1		reserved		
		0B	1		reserved		
		0C	1	00 - 01	Auto Power-Off	off, ON	
		0D	1	00 - 01	Speaker Output	off, ON	
		0E	1	00 - 01	MIDI Control	off, ON	
		0F	1		reserved		
		10	1		reserved		
		11	1		reserved		
		12	1		reserved		
		13	1		reserved		
		14	1		reserved		
		15	1		reserved		
		16	1		reserved		
		17	1		reserved		
		18	1		reserved		
		19	1		reserved		
		1A	1		reserved		
		1B	1		reserved		
		1C	1		reserved		
		1D	1		reserved		
		1E	1		reserved		
		1F	1		reserved		

Total Size = 32

MIDI PARAMETER CHANGE TABLE (Tone Generator)

Address (hex)			Size	Data Range (hex)	Parameter Name	Description	Notes
High	Mid	Low					
30	00	00	1	00 - 7F	Volume	0 - 127	This parameter can be set only via MIDI.
		01	1		reserved		
		02	1	00 - 04	organ voice type (WAVE)	H, V, F, A, Y	
		03	1	00 - 06	FOOTAGE 16'	0 (minimum: up) - 6 (maximum)	
		04	1	00 - 06	FOOTAGE 5 1/3'	0 (minimum: up) - 6 (maximum)	
		05	1	00 - 06	FOOTAGE 8'	0 (minimum: up) - 6 (maximum)	
		06	1	00 - 06	FOOTAGE 4'	0 (minimum: up) - 6 (maximum)	
		07	1	00 - 06	FOOTAGE 2 2/3'	0 (minimum: up) - 6 (maximum)	
		08	1	00 - 06	FOOTAGE 2'	0 (minimum: up) - 6 (maximum)	
		09	1	00 - 06	FOOTAGE 1 3/5'	0 (minimum: up) - 6 (maximum)	
		0A	1	00 - 06	FOOTAGE 1 1/3'	0 (minimum: up) - 6 (maximum)	
		0B	1	00 - 06	FOOTAGE 1'	0 (minimum: up) - 6 (maximum)	
		0C	1	00 - 01	Vibrato/Chorus Select (VIBRATO/CHORUS SWITCH)	VIBRATO, CHORUS	
		0D	1	00 - 04	Vibrato/Chorus Depth (VIBRATO/CHORUS DEPTH)	0 (no effect) - 4	
		0E	1	00 - 01	Percussion ON/OFF (PERCUSSION ON/OFF SWITCH)	OFF, ON	
		0F	1	00 - 01	Percussion Type (PERCUSSION TYPE SWITCH)	A, B	
		10	1	00 - 04	Percussion Length (PERCUSSION LENGTH)	0 - 4	
		11	1	00 - 03	Rotary Speaker Speed (ROTARY SPEED)	OFF, STOP, SLOW, FAST	
		12	1	00 - 7F	Distortion Drive (EFFECT DIST)	0 - 127	
		13	1	00 - 7F	Reverb Depth (EFFECT REVERB)	0 - 127	
		14	2		reserved		

Total Size = 22

MIDI Implementation Chart

YAMAHA [Mobile Mini Keyboard]
Model reface YC MIDI Implementation Chart

Date :23-MAR-2015
Version : 1.0

Function...	Transmitted	Recognized	Remarks	
Basic Channel	Default Changed	1 1 - 16	1 - 16 1 - 16	
Mode	Default Messages Altered	3 x *****	1 1,3 x	
Note Number : True voice	24 - 108 *****	0 - 127 0 - 127	Transpose	
Velocity	Note ON Note OFF	o 9nH,v=1-127 x 9nH,v=0	o v=1-127 x	
After Touch	Key's Ch's	x x	x x	
Pitch Bend		x	o	
Control Change	1 7 11 64 18,19 77,79,80 91 102-113	x x o x o *1 o *1 o *1 o *1	o o o o o *1 o *1 o *1 o *1	Modulation Wheel Main Volume Expression Sustain Sw
Prog Change : True #	x *****	x x		
System Exclusive		o	o	
Common : Song Pos. : Song Sel. : Tune	x x x	x x x		
System Real Time : Clock : Commands	x x	x x		
Aux Messages : All Sound Off : Reset All Cntrls : Local ON/OFF : All Notes OFF : Active Sense : Reset	x x x x o x	o (120,126,127) o (121) x o (123-125) o x		
Notes:*1 Transmitted and recognized if MIDI control mode is on.				

Mode 1 : OMNI ON , POLY
Mode 3 : OMNI OFF, POLY

Mode 2 : OMNI ON ,MONO
Mode 4 : OMNI OFF,MONO

o : Yes
x : No